

Automist Systems

Installation and Product Manual

Contents

- Installation Suggestions
- Assembly - Installation Instructions
- Timer Diagrams/Programming
- Initial Filling, Refilling, Water Filtering
- System Winterizing
- Reservoir Lid Diagram
- Pump Plumbing Diagram
- Nozzle Assemblies / Nozzle Cleaning
- Float Cord Assembly Diagram / Suction Filter
- Spray Usage Chart
- Troubleshooting
- Warranty

Installation Suggestions

INDOOR APPLICATIONS

- Put the pumping system/reservoir in an area that has access to a 110 volt outlet and a water supply. If the installation is in a large facility: the pumping system/reservoir should be placed as close to the center of the facility as possible. Or the shortest distance to the most distant nozzle. This will keep line pressure loss to a minimum.
- If there is **no** air movement in the facility, and ceiling height is under 10 ft., tilt nozzles at alternating 30 degree angles whenever possible. This will improve lateral movement of the insecticide spray.
- If windows and doorways are **not** open, or if there is no air movement in the building, it is suggested that a fan or fans be installed for air circulation. This will also help with spray dispersion and provide increased insect kill.
- **Do not** place nozzles in front of or with-in 10 ft. of exhaust fans.
- **Do not** place nozzles to spray directly on drinking cups, feed mangers or bunks.
- Nozzles should be centered between and a minimum of 3 ft. above any dairy cows.

OUTDOOR APPLICATIONS

- For very large areas that require long runs of tubing, more than one pumping unit may be needed to maintain proper line pressure.
- **Do not** place nozzles to directly spray on to live plants. Drift and over spray is acceptable. The burning of foliage is an indicator that a spray nozzle may be spraying on a plant or plants. Most plants are very hardy toward the water-based pyrethrin insecticides used. Some plants that may be affected are: Queen Elizabeth Rose, Mandy Crape Myrtle, Formosa Azalea, Japanese Boxwood, Tam Juniper, Dwarf Youpon
- **Do not** place nozzles within close proximity of decorative ponds or ponds that contain live fish. **Most all insecticides are toxic to fish.**
- **Do not** place nozzles close to large bodies of water such as rivers, lakes or other. Most labeling forbids the use of insecticides within the close proximity of open bodies of water.
- When pyrethrin is used outdoors, make sure black colored tubing is used. Pyrethrin does biodegrade in direct sunlight.

Assembly/ Installation



1. Unpack materials and check that all pieces have arrived in good condition. System box should include:

- Pumping unit (motor, timer, pump on bracket)
- Suction tubing attached to suction filter, float & weight
- Gauge
- 4 - 1/4" bolts
- 4 - 1/4" nuts
- 8 - 1/4" flat washers
- short tubing for return line
- May also include wireless remote and antenna



2. Secure the timer, motor & pump assembly bracket to the reservoir lid using the supplied 4 - 1/4" x 3/4" bolts, 4 - 1/4" nuts and 8 - flat washers (see reservoir lid diagram for location). Tighten firmly with a wrench.



3. Screw the gauge in to the top of the pump plumbing assembly. Using a wrench - tighten securely making sure the gauge is facing forward.



4. Using the reservoir lid diagram locate the "suction line" hole in the lid. Using your fingers, push the supplied tube/suction line (long - with float switch attached) through the reservoir lid from the bottom side and up into the elbow fitting (closest fitting to the pump, see picture at the left) until it is secure. Remember - push the tubing firmly in to the fitting, making sure it is secure. No tools are necessary.



The suction line, filter, float and weight should be positioned as in the picture to the left. Always check to see that the black float bulb is not restricted in its movement. It should be able to move freely. This black bulb is the float switch. When the bulb is facing up the system can be activated. When the liquid gets low and the bulb lays on its side or faces down, the system will be deactivated.

Assembly/ Installation Continued



5. Using the reservoir lid diagram, locate the “return line” hole in the lid. Using your fingers, push the tube/return line (short) through the reservoir lid from the bottom and up into the adjustment valve fitting (farthest from the pump), make sure it is secure. Remember - push the tubing firmly in to the fitting, making sure it is secure. No tools are necessary.

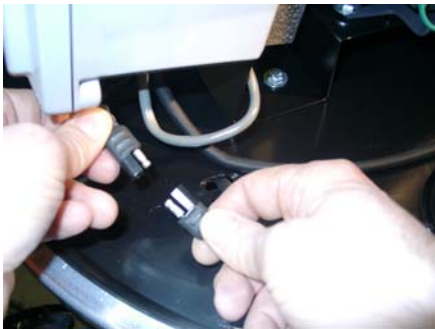

6. Next, insert the black electrical cord from the float switch (this cord has a molded connector on it and is attached to the suction line) through the reservoir lid from the bottom. Plug the molded connector from the float switch into the matching molded connector on the bottom of the timer enclosure making sure that the molded connectors are securely pushed together tight.



7. Secure and/or install all nozzle assemblies or risers in the installation area using electrical staples, plastic ties, loop clamps or other fasteners. Outdoor installations may require more sophisticated planning and installation techniques.



8. Making sure the tubing is cut straight, attach a coil of tubing to the output pressure fitting located on the pump, see picture to the left. Push the tubing into the fitting firmly. Run the tubing from the pumping unit out to the first nozzle assembly or to the proper center fitting, which ever applies to your system, refer to how your system was designed. Attach a fastener to the tubing approximately every 4-6 feet between nozzles to prevent the lines from sagging. Continue installing the tubing from one nozzle assemblies to the next, following your system design, until all nozzle assemblies are plumbed with tubing.

Assembly/ Installation Continued



9. The system is now ready to test. Remove the 2" filler cap located on the top of the reservoir lid. Fill the reservoir 1/2 full with filtered water (see initial system filling page). Replace the 2" filler cap or lid. Plug the systems power cord into 110 Volt outlet. Push the manual button and activate the system. With the system running, use your fingers or a wrench to turn the pressure adjusting nut in a clockwise direction to increase the pressure or counter-clockwise direction to decrease the pressure until the gauge reads 170 - 180 PSI. The 170 -180 PSI will not be reached until the system purges all air out of the tubing lines and nozzles. While all nozzles are operating, check that there are no leaks at any connections. If no leaks are found, unplug the power cord and once again remove the 2" filler cap or lid.

10. With the filler cap removed, add your insecticide concentrate according to the instructions on the insecticide label, then continue to add more filtered water until the solution is about 5 inches from the top of the reservoir lid. Replace the filler cap or reservoir lid.

11. Now determine how many spray cycles are desired per day and at what times they should occur. Normally 3 - 6 spray cycles per day indoors for flies, 2 - 3 spray cycles per day outdoors for mosquitoes. Spray cycles for flies should be set to run between 6 AM and 7 PM daily, spray cycles for mosquitoes should be set to run early morning and late night.

12. Program the timer to activate the proper amount of spray cycles for your application. See pages "Standard Timer Assembly Programming" or "Digital Timer Assembly Programming".

NOTE: When the spray solution in the reservoir reaches its low limit, the float switch inside the barrel will disengage the motor to protect the pump and you will need to refill the reservoir (follow refill directions). **It is very important not to run the system completely out of liquid. Running the pump without liquid will result in damage to the pump.**

If power is lost due to storms, etc., when power is restored simply rotate the large clock timer dial clockwise to reset the time of day and normal operation will continue.

Standard Timer Assembly Programming

Set time of day & number of spray cycles here.

Set spray duration here.



Push here for manual spray cycle.

Push the white tabs on the clock timer in an outward direction for each desired spray cycle time (see picture above). When the timer tabs are positioned, rotate the timer dial in a clockwise direction **ONLY**, to set the correct time of day.

Next, set the small timer dial (small black knob) to the desired amount of spraying time, normally about 30 - 60 seconds.

Plug the power cord back into a 110 volt outlet. The system is now operational and will spray automatically at the preset intervals.

Digital Timer Assembly Programming

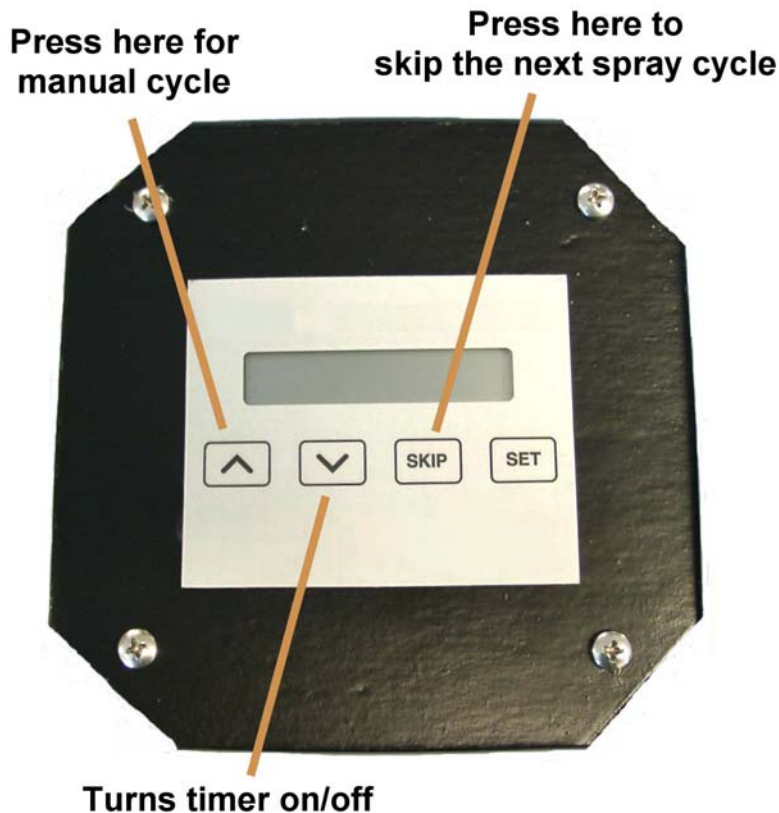

1. Start by setting the time of day. Push and hold the "set" key. The display will read "set hour". Press the up/down keys to the correct hour of day.
2. Press the "set" key to advance to minute of day. The display will read "set min". Press the up/down keys to the correct minute of day.
3. Press the "set" key to advance to AM/PM. The display will read "set AM/PM". Press the up/down keys to select between AM or PM.
4. Press the "set" key to advance to number of spray cycles per day. The display will read "# cycles". Press the up/down keys to select between 1 and 10.
5. Press the "set" key to advance to the spray cycle length. The display will read "set spray". Press the up/down keys to select the desired spray cycle length. The spray cycles start at 15 seconds and continue in 15 second blocks—15, 30, 45, 60, 75...240.
6. Press the "set" key to advance to the first spray cycle time. The display will read "prog 1 hour". Press the up/down keys to select the hour of the spray cycle.
7. Press the "set" key to advance to the minute of prog 1. The display will read "prog 1 min". Press the up/down keys to select the minute of the spray cycle.
8. Press the "set" key to advance to set AM/PM of prog 1. The display will read "prog 1 AM/PM". Press the up/down keys to select AM or PM of the spray cycle.
9. Repeat steps 6, 7 and 8 for each spray cycle. After all spray cycles are programmed, press the "set" key to return to the beginning screen and the current time of day. The timer is now programmed and ready to spray on an automatic schedule.

Change the time of day or reset previously programmed settings, push and hold the "set" key. Continue with directions above.

Initial System Filling

When filling a system, water quality needs to be considered. Poor water quality can affect the systems performance. Sediment, hard water or other impurities can, over time, clog nozzles. A simple hexa phosphate filter that screws on the end of a garden hose, like the one below (or similar) can eliminate a large portion of water impurities. We offer this style of filter for a minimal cost. They can be used for several refills before it needs to be discarded.



Make sure the systems electrical cord is unplugged from it's outlet, next fill the reservoir 1/2 full with filtered water, then add the insecticide concentrate (slowly), continue to add filtered water until the liquid reaches a point about 5 inches from the top of the reservoir. When the reservoir is full of the solution, stir thoroughly.

- ◆ It is a violation of Federal Law to use insecticides in a manner inconsistent with their labeling.
- ◆ As with an insecticide, always wear goggles, face shield or safety glasses. You should also wash thoroughly with soap and water after handling and remove any contaminated clothing and wash before reuse.
- ◆ Always store and dispose of any pesticide container by the approved State and Local procedures in your area.

System Refill

When the liquid in the reservoir becomes low, the system will automatically shut itself off. This is a safety precaution - running the pump dry can cause damage and void warranty.

Make sure the systems electrical cord is unplugged from the outlet. When adding the water, fill the barrel to approximately 1/2 full with filtered water (as described above), then add the insecticide concentrate (slowly), continue to add filtered water until the liquid reaches a point 5 inches from the top of the reservoir. After filling, stir the solution thoroughly.

System Winterizing

It is always best before winter arrives, if possible, to run the system to a point where the liquid is at its lowest point in the reservoir.

1. Unplug the systems power cord.
2. Remove the steel band from the reservoir lid.
3. Remove the reservoir lid (with pumping unit still attached) from reservoir or slid it to the side making sure it does not fall into the reservoir.
4. Pull the suction line with filter and float assembly out of the liquid in reservoir.
5. Make sure you are using an environmentally safe product to winterize your system such as windshield washer fluid. Dump the windshield washer fluid in to a one gallon or larger pail, then place the suction line into the pail, also making sure that the return line discharges into the same pail. **DO NOT USE ANTI-FREEZE PRODUCTS THAT CONTAIN PROPYLENE GLYCOL FOR WINTERIZING.** Propylene Glycol will damage the internal seals of the pump and void the warranty.
6. Plug the systems power cord into an outlet. Manually run the pumping unit until the windshield washer fluid has filled all tubing lines and nozzles. Once all the insecticide has been purged and you see the windshield washer fluid spraying from all nozzles unplug the power cord. **(Do not run the pump dry.)**
7. Next, pull the suction line out of the windshield washer fluid. Using a cable tie, rope or like method, tie the suction filter and float to the suction tubing just under the lid. **(Do not allow the filter and float to stay in the liquid over winter months. Freezing will damage them.)**
8. To de-winterize the system, stir the insecticide in the reservoir, untie and place the suction filter & float assembly in the insecticide liquid... plug the power cord in ... set the time of day on the clock timer... set pins for the spray cycles desired... start power unit manually and run it until all windshield washer fluid is purged from the system. The system is now ready for automatic operation.

DO NOT USE ANTI-FREEZE PRODUCTS THAT CONTAIN PROPYLENE GLYCOL. PROPYLENE GLYCOL will damage the internal seals of the pump and void the warranty.

Reservoir Lid

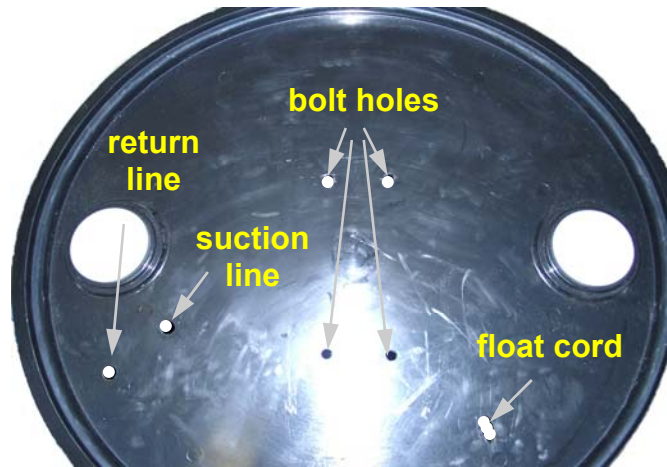

Front of Barrel

Pump Plumbing

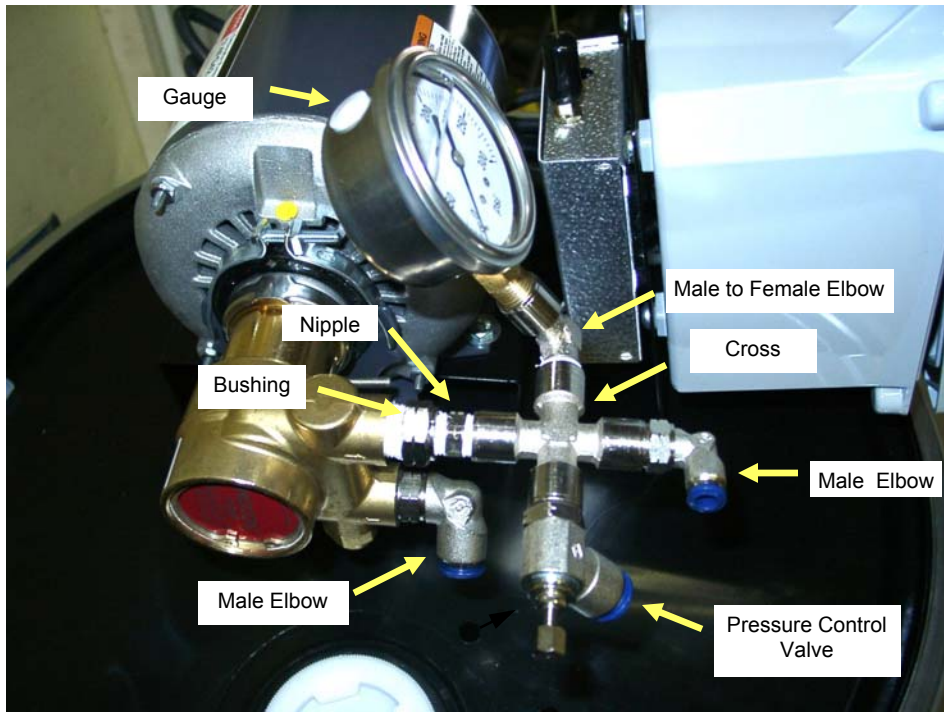

Nozzle Assemblies

Tee Nozzle



Elbow Nozzle



Straight Nozzle



45 Degree Tee Nozzle



45 Degree Elbow Nozzle



45 Degree Straight Nozzle



Nozzle Cleaning

Nozzles over time do need cleaning or worst case - replacing. The time in-between cleaning or replacing nozzles can depend on water quality. As seen in the picture each nozzle has its own filter that stops small debris from entering the nozzle and clogging the orifice.



Cleaning the Hago 4023 nozzle can be accomplished a number of different ways. The most common way to clean nozzles is to disassemble the nozzle and blow the housing out with compressed air. Many users have found that soaking the parts in a liquid lime and calcium removers helps to loosen hard water deposits and impurities. Old nozzles or nozzles that have been sitting without use for an extended period of time may accumulate a dried liquid near the nozzle orifice that can block the spray from exiting. A razor-blade makes a good tool for scraping the build-up from the nozzle tip

Float Cord & Suction Filter Assembly

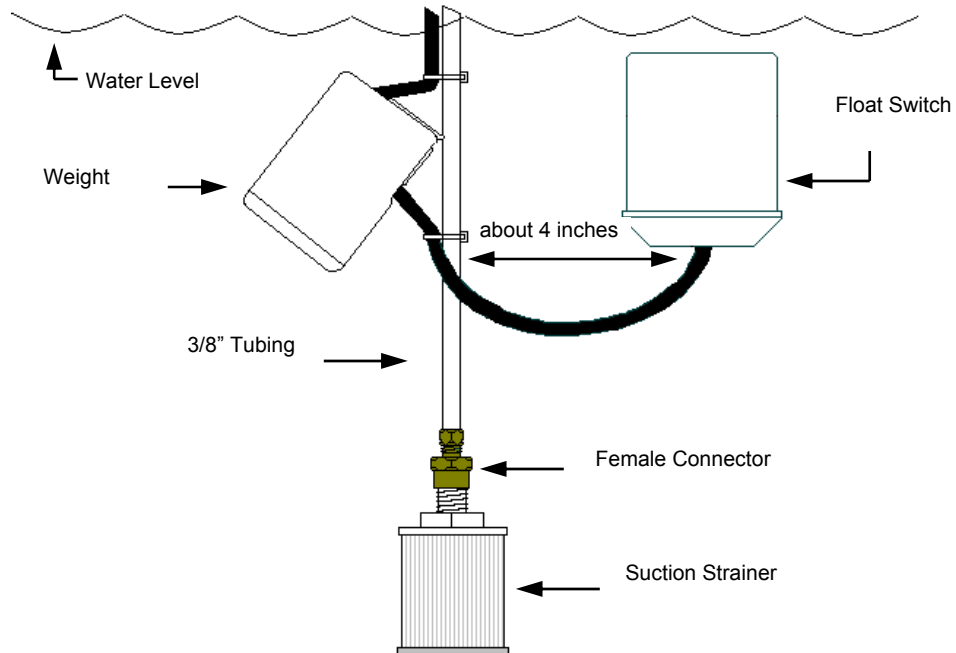

Filtration is important for proper operation. Our systems have a 100 mesh filter on the suction line inside the reservoir. This is a precaution to prevent any large particles from getting sucked into the pump.

Under normal operation the suction filter should be changed once every year to keep the proper flow without restrictions to the pump.



System Spray Usage

Spray Rates

	Seconds to spray	Spray Rate	Seconds to spray	Spray Rate
PSI				
160	37	1 oz	56	1.5 oz
170	36	1 oz	54	1.5 oz
180	35	1 oz	53	1.5 oz
190	34	1 oz	51	1.5 oz

Example: A systems set at 170 psi with a spraying time interval of 54 seconds will use/spray 1.5 ounces per nozzle.

Gallons of spray solution at one ounce per cycle Cycles Per Day

	1	2	3	4	5	6
5	.037	.078	.117	.156	.195	.234
6	.047	.094	.140	.187	.234	.281
7	.055	.109	.164	.218	.273	.328
8	.062	.125	.187	.250	.312	.374
9	.070	.140	.211	.281	.351	.421
10	.078	.156	.234	.312	.390	.468
11	.086	.172	.257	.343	.429	.515
12	.094	.187	.281	.374	.468	.562
13	.101	.203	.304	.406	.507	.608
14	.109	.218	.328	.437	.546	.655
15	.117	.234	.351	.468	.585	.702
20	.156	.312	.468	.624	.780	.936
25	.195	.390	.585	.780	.975	1.170
30	.234	.468	.702	.936	1.170	1.404
35	.273	.546	.819	1.092	1.365	1.638
40	.312	.624	.936	1.248	1.560	1.872
45	.351	.702	1.053	1.404	1.755	2.106
50	.390	.780	1.170	1.560	1.950	2.340
60	.468	.936	1.404	1.872	2.340	2.808
70	.546	1.092	1.638	2.184	2.730	3.276
80	.624	1.248	1.872	2.496	3.120	3.744
90	.702	1.404	2.106	2.808	3.510	4.212
100	.780	1.560	2.340	3.120	3.900	4.680

This chart is based on the following:
 180 lb. operating pressure
 30 second spray cycles

TroubleShooting

<u>Problem</u>	<u>What Could Be Wrong</u>	<u>How To Fix</u>
The System will not turn on.	Insecticide level is to low. Float switch (inside the reservoir) is stuck in a downward position.	Refill insecticide reservoir. Release float from stuck position.
The clock timer keeps time, but does not operate the System at preset times.	Possible internal/relay timer problem	Contact a representative.
The System operates at normal pressure, but nozzles do not spray.	Nozzle tips may be plugged with debris.	Clean or replace nozzle tips. Make sure filtered water is used to minimize clogging problems.
The System operates, but has low or no pressure.	Pump may be defective. Needle valve on pump is in an outward position. Suction filter (inside of reservoir) is plugged with debris. Air leak on a fitting in the System. Especially the suction fitting on the pump. Tubing may be damaged.	Replace pump. Turn needle valve in until pressure returns to 170 psi. Remove suction filter, clean or replace. Check fittings, especially suction fitting on pump. Check for damaged or leaking tubing.
The pump/motor surges on - off, on - off.	The liquid may be low and the return liquid is hitting the black float bulb.	Reposition the return line so that the liquid is not hitting the float bulb.
Remote control does not work.	Battery in the remote may be dead.	Check battery, if low or dead, replace the battery.
Digital timer is operating incorrectly.	Power loss combined with batteries in back up being dead.	Test and replace batteries in back up if needed. Set the timer back to defaults by pushing and hold down the set button while plugging in the power cord. The timer display should now say "Defaults ?". Press the set button and the timer will return to the default settings. Re-program the timer

If a problem can not be found or fixed, contact a representative for more information. When calling about a problem, describe the problem in detail and the steps you've done to try to correct it.

Warranty

United Spray System, Inc. guarantees its equipment to be free from defects in workmanship for a period of **one year from the date of purchase** by the end user. United Spray Systems, Inc. agrees to repair or replace at no charge, except shipping and handling, any part or parts found defective in normal use during the warranty period.

The enclosed warranty card must be filled out and returned within 30 days to validate warranty.

Repair service performed by parties other than authorized sales representatives of United Spray Systems, Inc. renders this warranty null and void; abusive or negligent use also invalidates this warranty. The customer agrees that no other remedy (including, but not limited to *claims for incidental, consequential, or special damages, or any cause, loss, action, claim or damage, including loss of time, whatsoever, or injury to person or property, or any economic loss*) shall be available, whether said claims be asserted on the basis of warranty, negligence, strict liability or otherwise. *United Spray Systems, Inc. warranty hereunder is expressly in lieu of all other warranties expressed or implied, including any warranties or merchantability and fitness for a particular purpose. All of such other warranties being hereby expressly excluded.*

***The disassembly of the timer assembly
or pump voids all warranty coverage.***