



Gas Grills

Models A-30 and A-40

ASSEMBLY, OPERATING
& MAINTENANCE INSTRUCTIONS



PATIO COMFORTS
www.patiocomforts.com
Toll-Free: 1-877-264-3794
customerservice@patiocomforts.com
PO. Box 340281
Austin, TX 78734



Please note: We have made our catalogs, specification sheets, and other materials relating to our line of outdoor cooking products as comprehensive and accurate as possible. We are constantly trying to improve all aspects of our products and therefore, reserve the right to make changes anytime, without notice. Because product improvements may have been made since the time our materials were printed, please check with your Authorized PGS Dealer or Distributor, if you have any specific questions concerning our products. We are dedicated to producing the finest leisure gas appliances for the home.

Revised 02/2009

TABLE OF CONTENTS

Safety Responsibilities, Warning Symbol	Page 4
Grill Model Identification (Location of Serial Number)	Page 4
Very Important Safety Tips & Warnings.....	Pages 5 & 6
Liquid Propane Gas Safety, Connections, Handling and Storage	Pages 7 & 8
Natural Gas Pressure Requirements.....	Pages 8 & 9
Definition of Key Terms	Page 9
Required Tools	Page 10
Part Numbers & Descriptions	Page 10
Parts Breakdown	Page 11
Post and Base (MPB) Assembly Instructions	Pages 12 & 13
Permanent Post Installation (48PP)	Page 13
Column to Base Kit Assembly Instructions (A-NB,A-LC and A-NC)	Pages 14 & 15
Grill Head Assembly	Pages 16 & 17
Connecting the Gas Supply	Pages 16 & 17
Ignitor Assembly	Page 17
Side Shelf Installation	Pages 17 & 18
Finish Assembly.....	Page 18
Lighting Your Grill / If Burner Fails to Light.....	Pages 18 & 19
Periodic Cleaning.....	Pages 19 & 20
Flashback (Spider Fires).....	Page 20
Electrode Adjustment.....	Page 20
Flare Ups	Page 21
Grease Cup Clean Out	Page 21
Flame Adjustment.....	Pages 21 & 22
Helpful Hints	Page 22
Orifice Engagement	Page 22
Gas Grill Conversion.....	Page 22
Trouble Shooting	Page 23
Proper Tube Bending.....	Page 24
Cooking Tips and Temperature Guide.....	Pages 24, 25 & 26
Warranty Information	Page 27

 **SPECIAL ATTENTION:**
THIS SYMBOL NOTES SAFETY RELATED ITEMS OR PRODUCT WARNINGS

IT IS YOUR RESPONSIBILITY TO:
ASSEMBLE, INSTALL, LEAK CHECK, CARE AND OPERATE YOUR GAS GRILL. SAVE THESE INSTRUCTIONS FOR FUTURE REFERENCE.

FOR YOUR SAFETY IF YOU SMELL GAS:

1. SHUT OFF GAS TO THE APPLIANCE.
2. EXTINGUISH ANY OPEN FLAME.
3. OPEN LID.
4. IF ODOR CONTINUES, IMMEDIATELY CALL YOUR GAS SUPPLIER.

THIS GAS GRILL IS DESIGNED FOR OUTDOOR USE ONLY

FOR YOUR SAFETY:
DO NOT STORE OR USE GASOLINE OR OTHER FLAMMABLE VAPOR AND LIQUIDS IN THE VICINITY OF THIS APPLIANCE.

THIS GRILL IS NOT INTENDED FOR USE ON A BOAT/HOUSE BOAT OR RECREATION VEHICLE

STORE THE LP GAS (PROPANE) CYLINDER OUTDOORS IN A WELL-VENTILATED SPACE. DO NOT STORE A PROPANE GAS CYLINDER IN DIRECT SUNLIGHT. DO NOT STORE EXTRA CYLINDERS IN CART OR NEAR GRILL. DO NOT STORE THE PROPANE CYLINDER ON ITS SIDE.

 **Teflon tape or pipe joint compound will be required on all steel pipe connections. Never use a sealer when your connection is brass to brass. Brass to brass is self-sealing. Using a sealant on a brass-to-brass connection may cause a leak!**

The grill itself is partially assembled, with the burner, venturi, ignitor, collector box, and ignitor lead wire installed. Take your time in assembly. Please read instructions thoroughly before starting assembly.

This manual is based on information available when the manual was printed. Continued improvements in

design could cause changes in the grill that may or may not be included herein. Please consult your authorized PGS dealer if you have any questions concerning assembly, installation or operation of your grill.



The display of a test agency certification seal on the product label indicates that the unit is constructed according to the certified testing agency.

MODEL IDENTIFICATION

A model number and the serial number on the vertical left hand side of the control panel identify your PGS Grill. TAKE THE TIME NOW TO RECORD THE MODEL AND SERIAL NUMBER OF YOUR GRILL IN THE SPACE PROVIDED BELOW. Always use both the model number and the serial number when calling or writing AEI about your PGS grill. We can be reached at: PO Box 16097, Irvine, CA 92623-6097 (949) 474-3070 FAX (949) 474-0559. Email: aEICORP@sbcglobal.net

PLEASE RETAIN INSTRUCTIONS FOR FUTURE REFERENCE, AND RETURN THE OWNERS REGISTRATION CARD IMMEDIATELY. RETURN OF WARRANTY CARD INSURES WARRANTY REGISTRATION. MAINTAINING YOUR SALES RECEIPT WILL EXPEDITE WARRANTY CLAIMS.

DATE PURCHASE: _____
DEALERSHIP: _____
CITY, STATE: _____
MODEL NUMBER: _____
TYPE OF GAS: NATURAL GAS ___ PROPANE ___
SERIAL NUMBER _____

The grill must be located no closer than 30" from any combustible surface above, behind or to the sides. The grill should not be located under overhead-unprotected combustible materials.



VERY IMPORTANT SAFETY TIPS AND WARNINGS

PGS IS MOST CONCERNED ABOUT THE SAFE USE OF OUR PRODUCT. THE FOLLOWING TWO PAGES ARE A SUMMARIZATION OF THE SAFETY TIPS FOUND THROUGHOUT THIS MANUAL. PLEASE TAKE THE TIME TO REVIEW THEM, AS THEY ARE CRITICAL IN THE ENJOYABLE USE OF YOUR GRILL. IMPROPER ASSEMBLY, NEGLIGENCE, OR INSUFFICIENT CARE OF YOUR PGS GAS GRILL MAY RESULT IN SERIOUS BODILY INJURY AND/OR PROPERTY DAMAGE.



GIVE THIS SYMBOL SPECIAL ATTENTION THROUGHOUT THIS MANUAL. IT NOTES SAFETY RELATED ITEMS OR PRODUCT WARNINGS

OUR GRILLS ARE TESTED IN ACCORDANCE WITH ANSI Z21.58A-2002*CGA 1.6A-M99 STANDARD FOR OUTDOOR GAS COOKING APPLIANCES. CHECK YOUR LOCAL BUILDING CODES FOR THE PROPER METHODS OF INSTALLATION. IN THE ABSENCE OF LOCAL CODES, THIS GRILL SHOULD BE INSTALLED IN COMPLIANCE WITH THE NATIONAL FUEL CODE NO. Z223.1-2002 AND THE NATIONAL ELECTRICAL CODE ANSI/NFPA NO. 70-2002. GAS GRILLS ARE NOT AGA DESIGN CERTIFIED OR RECOMMENDED FOR USE ON RECREATIONAL VEHICLES, PORTABLE TRAILERS, BOATS/HOUSE BOATS, OR ANY OTHER MOVING INSTALLATION.

- CALIFORNIA PROPOSITION 65 WARNING: THE BURNING OF GAS COOKING FUEL GENERATES SOME BY-PRODUCTS WHICH ARE ON THE LIST OF SUBSTANCES AND ARE KNOWN BY THE STATE OF CALIFORNIA TO CAUSE CANCER OR REPRODUCTIVE HARM. CALIFORNIA LAW REQUIRES THAT BUSINESSES WARN CONSUMERS OF POTENTIAL EXPOSURE TO SUCH SUBSTANCES. TO MINIMIZE EXPOSURE TO THESE SUBSTANCES, ALWAYS OPERATE THIS GAS GRILL ACCORDING TO THE USE AND CARE INSTRUCTIONS FOUND IN THIS MANUAL. BE CERTAIN TO PROVIDE ADEQUATE VENTILATION WHEN COOKING.
- WARNING: DO NOT TRY TO LIGHT THIS APPLIANCE WITHOUT FIRST READING: THE "LIGHTING YOUR GRILL" SECTION OF THIS MANUAL FOUND ON PAGE 21.
- DO NOT MODIFY ORIGINAL EQUIPMENT. YOUR GRILL HAS BEEN DESIGNED AND ENGINEERED TO OPERATE SAFELY AS OUTLINED IN THIS MANUAL. ONLY REPLACE COMPONENTS WITH GENUINE PGS REPLACEMENT PARTS, WHICH ARE AVAILABLE FROM YOUR LOCAL DEALER AND/OR DISTRIBUTOR. USE OF NON-GENUINE PARTS MAY RESULT IN INFERIOR PERFORMANCE AND/OR SAFETY HAZARDS AND WILL VOID THE WARRANTY.
- CHILDREN SHOULD NOT BE LEFT ALONE OR UNATTENDED IN AN AREA WHERE THE GRILL IS IN OPERATION. WE SUGGEST PLACEMENT OF YOUR GRILL WELL AWAY FROM AREAS WHERE CHILDREN PLAY. DO NOT STORE ITEMS THAT MAY INTEREST CHILDREN IN OR AROUND THE GRILL, IN THE CART, OR IN THE MASONRY ENCLOSURE. NEVER ALLOW CHILDREN TO CRAWL OR PLAY INSIDE A MASONRY ENCLOSURE.
- NEVER STORE ADDITIONAL OR EMPTY PROPANE CYLINDERS IN GRILL CABINET OR AROUND THE GRILL. DO NOT STORE A PROPANE CYLINDER INDOORS OR ON ITS SIDE. NEVER ALLOW A PROPANE CYLINDER TO BE OVERFILLED. NEVER USE A DENTED, RUSTY OR DAMAGED PROPANE CYLINDER. NEVER REPLACE THE SAFETY COUPLER FITTINGS ON THE GRILL WITH ANY OTHER CONNECTIONS.
- NEVER STORE POOL CHEMICALS OR OTHER FLAMMABLE MATERIALS IN ANY CABINET BELOW OR NEAR THE GRILL. NEVER ALLOW LOOSE CLOTHING, POTHOLDERS, SYNTHETIC MATERIALS, OR OTHER FLAMMABLE MATERIALS TO COME IN CONTACT WITH THE GRILL AND/OR ITS PARTS. FLAMMABLE MATERIALS COULD IGNITE AND CAUSE PERSONAL INJURY AND/OR PROPERTY DAMAGE.
- NEVER MOVE YOUR GAS GRILL WHEN OPERATING. NEVER MOVE GRILL WHEN HOT. NEVER COVER GRILL WHEN HOT.
- DO NOT HEAT UP UNOPENED FOOD CONTAINERS ON THE GRILL AS A BUILDUP OF PRESSURE MAY CAUSE THE CONTAINER TO BURST.
- THE LP CYLINDER THAT YOU USE WITH YOUR GRILL SHOULD BE EQUIPPED WITH AN OVERFILL PROTECTION DEVICE (OPD). IF YOU USE A TANK EXCHANGE SYSTEM, BE SURE TO EXCHANGE THIS TANK FOR ANOTHER TANK WITH THE SAME SAFETY SYSTEM.
- USE AN INSULATED GLOVE WHEN OPENING AND OPERATING THE GRILL. OPEN GRILL LID SLOWLY TO ALLOW HEAT AND SMOKE TO ESCAPE BEFORE FULLY OPENING.
- NEVER LEAN OVER HOT GRILL SURFACE OR LOOK DIRECTLY INTO GRILL WHEN ATTEMPTING TO LIGHT. THE GRILL HOOD MUST BE OPENED FULLY WHEN LIGHTING. BE SURE THAT ALL FAMILY MEMBERS ARE AWARE OF SAFE LIGHTING AND OPERATING PROCEDURES FOR THE GRILL.

- IF A PROFESSIONAL INSTALLER OR DEALER INSTALLS THE GRILL, BE SURE THAT HE SHOWS YOU WHERE YOUR GAS SUPPLY SHUT OFF IS LOCATED. ALL GAS LINES MUST HAVE A SHUT OFF THAT IS READILY AND EASILY ACCESSIBLE. IF YOU SMELL GAS, CHECK FOR GAS LEAKS IMMEDIATELY. CHECK ONLY WITH A SOAP AND WATER SOLUTION. NEVER CHECK FOR GAS LEAKS WITH AN OPEN FLAME.
- NEVER USE CHARCOAL, VOLCANIC ROCK, WOOD CHIP MATERIALS, OR NON-PGS BRIQUETTES IN YOUR GRILL.
- KEEP THE OPTIONAL ROTISSERIE MOTOR AND ELECTRICAL SUPPLY CORD AWAY FROM HEATED CASTING, COOKING GRIDS, OTHER HOT PARTS OR WATER. STORE ROTISSERIE MOTOR AND PARTS IN A DRY PLACE WHEN NOT IN USE.
- NEVER USE GRILL IN A WINDY AREA AND NEVER USE THE GRILL DURING AN EXTREMELY WINDY DAY. CLIMATIC CONDITIONS WILL IMPACT THE PERFORMANCE OF THE GRILL. IN CONSISTENTLY WINDY CONDITIONS, WE SUGGEST INSTALLING A SUITABLE WINDBREAK.
- ALWAYS ADHERE TO THE REQUIRED CLEARANCES FROM COMBUSTIBLES. THE GRILL IS DESIGNED FOR USE OUTDOORS ONLY; NEVER OPERATE IN GARAGE, BUILDINGS, SHED, BREEZEWAYS OR OTHER ENCLOSED AREAS.
- STORE YOUR GRILL IN A WELL-VENTED AREA. REMOVE THE LP CYLINDER, IF EQUIPPED WITH ONE, AND STORE IT OUTDOORS IN A WELL-VENTILATED AREA AWAY FROM HEAT AND WHERE CHILDREN MAY POSSIBLY TAMPER WITH IT.
- WHEN USING THE OPTIONAL SIDE BURNER KIT, USE POTS THAT HAVE FLAT BOTTOMS AND ARE LARGE ENOUGH TO COVER THE ENTIRE BURNER. ADJUST THE FLAME SO THAT IT ONLY HEATS THE BOTTOM OF THE POT OR PAN TO AVOID THE POSSIBLE LIGHTING OF CLOTHING. POSITION HANDLE IN A WAY THAT IT DOES NOT CONFLICT WITH THE OPENING AND CLOSING OF GRILL LID. YOU CANNOT OPERATE YOUR SIDE BURNER KIT AND ROTISSERIE MOTOR SIMULTANEOUSLY.
- GREASE IS EXTREMELY FLAMMABLE. LET HOT GREASE COOL DOWN BEFORE ATTEMPTING TO HANDLE OR DISPOSE. PLEASE CLEAN OUT YOUR GREASE TRAY OR GREASE CAN ON A REGULAR BASIS.
- NEVER COVER COOKING GRID WITH A MATERIAL THAT WILL TRAP HEAT BENEATH COOKING GRIDS, SUCH AS LARGE PANS OR ALUMINUM FOIL. HEAT REFLECTED BELOW MAY CAUSE DAMAGE TO ROCK GRATES, BURNERS, GAS VALVE ASSEMBLY AND POSSIBLY TO GAS TRAIN. YOU NEED ONLY TO "PRE-HEAT" YOUR GRILL FIVE TO SEVEN MINUTES BEFORE COOKING. YOU DO NOT NEED TO "BURN-OFF" YOUR GAS GRILL FOR EXTENDED TIMES AFTER USE.
- SPIDERS AND OTHER SMALL INSECTS CAN BUILD NESTS OR WEBS IN THE BURNERS OF YOUR PGS GRILL, WHICH WILL CAUSE GAS TO FLOW OUT FROM THE FRONT OF THE BURNER TUBES. THIS CAN CAUSE A FIRE TO BURN BEHIND YOUR CONTROL PANEL, THEREBY DAMAGING YOUR GRILL AND MAKES THE GRILL UNSAFE TO OPERATE. INSPECT YOUR GRILL TWICE A YEAR OR IMMEDIATELY WHEN SYMPTOMS APPEAR. SEE "FLASHBACK" ON PAGE 22.
- PLEASE REFER TO SPECIFIC SECTIONS OF THIS MANUAL (SEE TABLE OF CONTENTS) IF YOU HAVE QUESTIONS REGARDING DIFFERENT TYPES OF FUELS, LIGHTING, OR TROUBLE-SHOOTING. IF YOU HAVE QUESTIONS THAT ARE NOT ANSWERED IN THIS MANUAL PLEASE CALL YOUR LOCAL DEALER.
- THE GRILL MUST BE LOCATED NO CLOSER THAN 30" FROM ANY COMBUSTIBLE SURFACE ABOVE, BEHIND OR TO THE SIDES. THE GRILL SHOULD NOT BE LOCATED UNDER OVERHEAD-UNPROTECTED COMBUSTIBLE MATERIALS.
- KEEP THE AREA AROUND THE GRILL CLEAR OF COMBUSTIBLE MATERIALS, FLAMMABLE VAPORS OR LIQUIDS SUCH AS GASOLINE. THE GRILL SURFACES BECOME VERY HOT DURING USE. KEEP CHILDREN AND PETS AWAY. USE HOT PADS OR OVEN MITTS,

GAS

Both natural gas (NG) and propane gas (LP) have a long history of safe use when simple rules are followed. If not, there is danger of fire or explosion.

Check Local Codes. Consult your local LP dealer or Natural Gas Company listed in your local directory for recommended installation procedures and

regulations. In the absence of local codes, installation must conform to the National Fuel Gas Code, ANSI Z21.58a-1999*CGA 1.62-M99.



NEVER USE NATURAL GAS IN A UNIT DESIGNED FOR LIQUID PROPANE OR THE REVERSE. IF YOU WISH TO CONVERT YOUR GRILL FROM ONE TYPE OF GAS TO THE OTHER, PLEASE CONTACT YOUR LOCAL DEALER OR DISTRIBUTOR.

Never connect an unregulated propane gas cylinder or unregulated natural gas to your gas grill (Note: most homes equipped with natural gas have a regulator near the gas meter.

USER SAFETY INFORMATION OF PROPANE MODELS

Your PGS grill is designed to operate on Propane Gas regulated at a gas pressure of 11" water column (W.C.) (2.7kPa). If you are hooking your grill into "System LP" which fuels your home, please be certain that you are at this pressure.



Operating your grill at pressure higher or lower than recommended may damage the grill or result in a hazard or poor performance.

A regulator adjusted to this pressure must be installed in the gas supply line before the grill is connected to the propane source. PGS propane gas grills include an 11" W.C. regulator and a "TYPE II" Cylinder Connection Device. This system complies with the specifications and requirements of ANSI Z21.58a-1999*CGA 1.62-M99 standards. This system can only be used with a "quick couple" type of tank. Our regulated hoses include an excess flow safety system that will limit the flow of gas to your grill in the event of leaking gas or a damaged hose.

PLEASE NOTE. In the event that you inadvertently have the valves of your grill turned to the "ON" position, and then open the valve on top of your tank, the excess flow device will activate and shut off the flow of gas. If this should occur, turn the valves to the "OFF" position on your grill head, then the valve on the tank. Wait two minutes and then open the valve on the tank BEFORE turning the valves of your grill head. Always turn on the valve at the top of your tank and then the valves to your grill head to the "ON" position.

The safety system detailed above has been incorporated into your PGS gas grill to provide you

and your family the maximum in safety when operating the grill.

PLEASE DO NOT CHANGE THE LP HOSE OR USE WITH A STANDARD 20 LB. P.O.L. CYLINDER.



TURN VALVE THAT IS LOCATED AT THE TOP OF TANK TO "OFF" WHEN GRILL IS NOT IN USE.

DO NOT CONNECT THE GRILL TO A PROPANE GAS CYLINDER GREATER THAN 20 LB. CAPACITY.

PROPANE CYLINDER FILLING

Federal Law requires any tank used for a gas grill must include an overfill protection device. If you are uncertain whether your tank complies, check with selling dealer. Please do not allow a fueling station operator to change or modify this safety system on your propane cylinder.

When the hose is disconnected from the tank, the flow of gas is safely shut off. You must still shut off the main tank valve located at the top of the tank when transporting your tank or when the unit is not in use.

PROPANE CYLINDER FILLING AND HANDLING SAFETY TIPS

- Be certain tank is equipped with an overfill protection device.
- Do not modify hose or LP fittings. Contact a local dealer or distributor if tank, hose or fittings need replacement.
- If it is evident there is excessive abrasion or wear, or the hose is cut, it must be replaced prior to the grill being operated. Please see your local PGS dealer/distributor or call PGS for an exact replacement.
- Store propane tank outdoors in a cool, well-ventilated area. Never store extra tanks in, on, or around your grill.
- Turn off tank when not in use.
- Transport tanks upright ONLY.
- Never allow a tank to be overfilled. 100% full tank holds only 4.5 gallons of propane.
- Inspect your grill cabinet often to ensure that ventilation openings in sides and back of pedestal are free from debris and have proper air circulation.
- Never paint LP cylinder a dark color. This may cause OVERHEATING. Do not apply heat directly to tank.

- LP Gas is stored under high pressure and must be handled with care. Do not handle a tank roughly.
- Be sure your LP gas dealer checks the cylinder with a soapy solution for leaks after filling.
- Do not turn gas valve on unless connection between regulator and coupler is complete.
- Storage of your gas grill indoors is permissible only if the cylinder is disconnected, removed from grill and cylinder stored outdoors.



BEFORE ATTEMPTING TO LIGHT GRILL, BE CERTAIN THE GAS VALVE KNOBS ARE IN THE OFF POSITION. TURN TANK VALVE ON BY TURNING KNOB ON TOP OF TANK, COUNTER CLOCKWISE. CHECK ALL CONNECTIONS WITH A SOLUTION OF 50% LIQUID SOAP, 50% WATER. SOLUTION CAN BE SPRAYED ON WITH A SPRAY BOTTLE OR PAINTED ON ALL CONNECTIONS WITH A BRUSH. IF BUBBLES APPEAR THERE IS A LEAK, TURN OFF GAS, TIGHTEN FITTINGS AND REPEAT THIS CHECK.

The cylinder must be provided with a shut-off valve terminating in an LP-gas supply cylinder, valve outlet specified, as applicable, for Connection No. 510 in the Standard for Compressed Gas Cylinder Valve Outlet and Inlet Connections, ANSI/CGA-V-1, or Connection No. 600 in the Compressed Gas Association's Limited Standard Cylinder Valve Outlet Connection for Propane Small Valve Series or a combination LP-gas cylinder valve and quick-disconnect assembly complying with 1.5.5-c and a safety relief device making a direct connection with the vapor space of the cylinder.

The cylinder supply system must be arranged for vapor withdrawal and must include a collar to protect the cylinder valve. Special Note** All new tanks are filled with air, not propane. Air must be purged before the tank is filled. When purchasing an LP gas tank, be certain it meets all standards, and allow only a qualified LP-gas dealer to fill the propane gas cylinder.

PROPANE GAS CYLINDER



DISCONNECTED CYLINDER MUST NOT BE STORED IN A BUILDING, GARAGE OR ANY OTHER ENCLOSED AREA. BEFORE LIGHTING YOUR GRILL, INSPECT THE HOSE TO ENSURE THAT IT IS IN TACT AND THERE ARE NO LEAKS.

All LP-gas cylinders used with this grill shall be approximately 12" in diameter and about 18" in height. The maximum fuel capacity must be 20 lbs. of propane (47.7 lbs. nominal water capacity or 4.5 gallons). DO NOT connect your grill to a propane gas cylinder that exceeds this capacity.

All propane-gas cylinders used with the grill must be constructed and marked in accordance with the specifications for propane-gas cylinders of the U.S. Department of Transportation (DOT). In Canada, gas cylinders must meet CTC specs. Federal Law requires any tank used for a gas grill must include an overfill protection device.

All refillable propane-gas cylinders used with the gas grill must be inspected at every filling and must be re-qualified by a licensed LP-gas cylinder filler in accordance with DOT (US) or CTC (Canadian) requirements for LP-cylinders.

LP-Gas Tank Specifications:

Weight (filled)	40 lbs.	(18.14 kg)
Capacity	4.5 gallons	
Diameter (outside)	12 1/8"	(30.8 cm)
Height	18"	(45.7 cm)
Connection	TYPE QCC1	

NATURAL GAS MODELS

Your PGS gas grill has been designed and produced for outdoor use only! Every gas-burning appliance produces carbon monoxide and should not be allowed to accumulate in confined areas. **DO NOT OPERATE YOUR PGS GAS GRILL INSIDE A HOME, GARAGE, RECREATIONAL VEHICLE, BOAT/HOUSE BOAT, OR ANY OTHER ENCLOSED AREA.**

When choosing a location for your grill, you must locate it at least 30" away from any combustible material and out of traffic paths. The grill and its individual shutoff valve must be disconnected from the gas supply piping system during any pressure testing of that system at test pressures in excess of 1/2 psig (3.5kPa).

The grill must be isolated from the gas by closing its valves during any pressure testing of the gas supply piping system at test pressures equal to or less than 1/2 psig (3.5kPa). Piping system at test pressures equal to or less than 1/2

DEFINITION OF KEY TERMS

GRILL HEAD: Entire BBQ grill (lid & pit) that can be mounted on a variety of options.

GRILL MOUNT: Supports gas grill head, can be a post and base mount, a permanent post mounts pedestal mount (stationary or mobile) or built in frame inserted in a masonry enclosure.

COLUMN; Pedestal that support grill head when used with a base kit. Ours are either stainless steel of aluminum.

GRILL UPPER CASTING: Top (lid) of gas grill head, made of aluminum and powder coated black.

GRILL LOWER CASTING: Bottom (pit) of gas grill head made of aluminum and powder coated black.

BASE: Stationary or designed to be used with wheels made of aluminum and powder coated black.

VALVE: Device used to control amount of gas (and heat) grill produces.

ORIFICES: Openings at end of valve that restrict amount of gas going to BBQ.

VENTURI: Banana shaped tube that allows gas to flow from the valve to the burner.

FEEDLINE: Aluminum gas line from back to grill mount to bottom of valve. Used only on models that include pedestal.

HINGE PINS AND COTTER PINS: Hinge pin goes through lower and upper casting with cotter pins permanently holding.

GASKET: Insulator between pedestal and base.

WATER COLUMN (W.C.): A measurement of gas pressure.

YOU WILL NEED THE FOLLOWING TOOLS TO ASSEMBLE YOUR PGS GAS GRILL:

- 1 - Mallet or Hammer
- 2 - 6" Adjustable Wrenches
- 50% Soap and Water Solution

- 1 - Med. Phillips Head Screw Driver
- 1 - Small Roll of Teflon Tape (Natural Gas Only)
- 1 - Spray bottle or brush

Having these additional tools on hand will make assembly easier:

1 - 1/2" Socket and Drive

1 - 7/16" Socket and Drive

REF#	MISC HARDWARE	QTY	PART NUMBER
AA	SIDE SHELF BOLTS 7/16 x 1/4/20 x .75"	4	190170
AB	CONTROL PANEL HEX BOLTS 7/16 x 1/4/20 x .75"	2	190170
AC	HEAD HEX BOLTS 7/16 x 1/4/20 x 1.25"	4	190050
AD	BASE HEX BOLTS 1/2 x 5/16 x 3/4	6	190010
AE	STIFF BRKT / HEAD BOLT 1/4 x 20 x 1.25"	2	190050
AF	STIFF BRKT / PANEL BOLT 1/4 x 20 x .5"	2	B1401
BB	FLAT WASHER 5/16"	6	190020
BC	LOCK WASHER 5/16"	6	190030
CA	NUT 1/4 LOCKING KEP	10	N1404
CB	NUT 5/16	6	190040

Hardware is not pictured

PLEASE NOTE: ALL PARTS MAY NOT COME WITH ALL MOUNTING OPTIONS

PART NUMBERS AND DESCRIPTIONS

REF#	DESCRIPTION	QTY	MODEL A40	MODEL A30
1	UPPER GRILL CASTING	1	140010	130010
2	LOWER GRILL CASTING	1	140020	130020
3	WARMING RACK	1	A140071	A130071
4	COOKING GRID	2	A140081	A130081
5	ROCK GRATE (porcelain)	1	A140100	A130100
6	BURNER ASSEMBLY	1	140110	130110
7N	VALVE ASSEMBLY FOR NG	1	A140120	A130120
7L	VALVE ASSEMBLY FOR LP GAS	1	A140125	A130125
8	CONTROL PANEL ONLY	1	A140150	A130150
9	SIDE HANDLES	2	100050	
10	BOLT & STAR WASHER F/HANDLE	2	100060	
11	CERAMIC ROCK	1	AROCK40 / MR84	AROCK30 / MR56
12	CONTROL KNOBS	2	A100130	
13	IGNITOR MODULE	1	A100140	
14	IGNITOR WIRE (For A30 OR A40)	1	A100145	
15	COLLAR BOX	1	A100301	
16	STAINLESS STEEL COLUMN	1	A100270	
17	BLACK COLUMN	1	A100275	
18R	RIGHT SIDE SHELF A30, A40	1	ASHELF RH	
18L	LEFT SIDE SHELF A40 (A30 option)	1	ASHELF LH	
19	ALUMINUM BASE FOR PORTABLE (ALC ANC)	1	A100030	
20	ALUMINUM BASE FOR PATIO (ANB)	1	A100035	
21	AXLE CAP COVERS	2	A100230	
22	1/2"X 20.75" ALUMINUM AXLE	1	A100240	
23	DEEP TREAD 7 5/8" POLY WHEEL	2	A100250	
24	LP HOSE & REGULATOR ASSY (HR 4B)	1	A100510	
25	12" NATURAL GAS HOSE KIT	1	QD12	
26	HINGE PIN (CLEVIS)	2	190090	
27	CASTER SWIVEL LOCKING	2	109925	
28	TANK STRAP – STAINLESS STEEL	1	A100235	
29	COTTER PIN HAIR PIN CLIP	4	190100	
30	COLLECTOR BOX FOR IGNITOR	1	A100137	
31	POST ONLY 4" x 24" FOR AMPB	1	109972	
32	ALUMINUM BASE ONLY SQUARE (AMPB)	1	109971	
33	48" POST ONLY FOR GROUND INSTALL	1	100300	
34	FEEDLINE FOR PERMANENT POST or AMPB	1	100310	
35	STIFFENING BRACKET SET F/ CONTROL PANEL	1	100305	
37	GREASE TRAY/ GREASE CUP	1	100837	
38	RUBBER GASKET (PAIR) PEDESTAL/BASE N/P	1	100269	

Fig. 7 1. Remove Clip And lift Burner Out

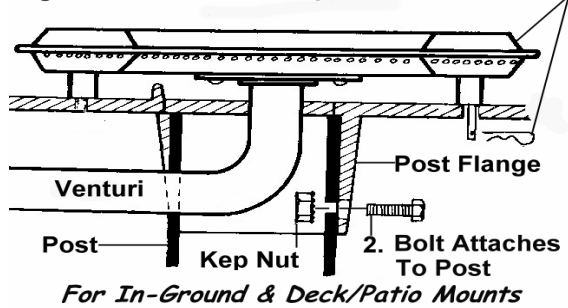

3. Mount the grease cup holder to the rear flange hole with a 1/4 - 20 x 3/4" bolt and 1/4-20 Kep nut. The grease cup holder is supplied with the grill head.

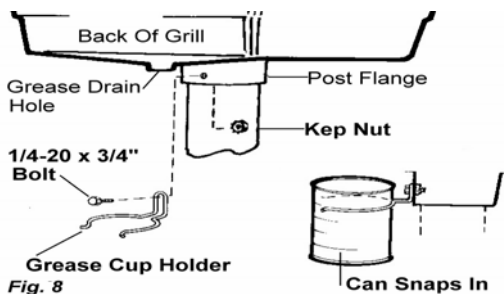

When you complete the mounting assembly go to the Grill Assembly Section and assemble the grill head.

In-Ground Mounting Assembly Instructions (48PP)

Either the A30 or A40 may be mounted on a permanent post (48PP). The gas supply can be natural gas or system LP gas. The grill head should not be attached to the post until the post is permanently cemented in the ground.

Please check to be sure that all parts are included before proceeding. Contact your dealer if any parts are missing.

Parts	Quantity
4' Post	1
Post access door	1
28" Stainless Steel Tubing	1
Stainless Steel Grease Cup	1
Stainless Grease Cup Holder	1
1/4 - 20 x 3/4" Hex Head Bolts	3
1/4 - 20 Kep Nuts	3

Step 1: In-Ground Mounting Installation (Fig. 9)

1. Dig a posthole about 8 inches wide by 2 feet deep.
 Caution: Locate the hole so that the mounted grill head has a clearance of 18 inches away from any combustible object or surface; back, left or right. Center the post in the hole and plumb it. Pour in cement (gravel) up to the gas line access hole.

Keep in mind that the gas line access hole is on the back of the post and the notch at the top if facing front. Recheck plumb and allow cement to set.

2. Run the gas supply line into the post access hole (just above the cement). Make a 90° bend to reach the access door opening.

The gas supply line should be trenched at least 18 inches below the surface of the ground to prevent damage from digging. CAUTION: The gas supply line must be regulated (in the case of natural gas that means connected after your gas meter and regulator) and that you have an easily accessible shut-off valve.

3. At the access door connect a 3/8" flare coupling (not supplied by PGS) to the gas supply line and Stainless Steel tubing. Position the tubing in the top notch of the post. Bend the tubing at the top end to match the Feed Line of the grill valve. Do not kink the tubing.

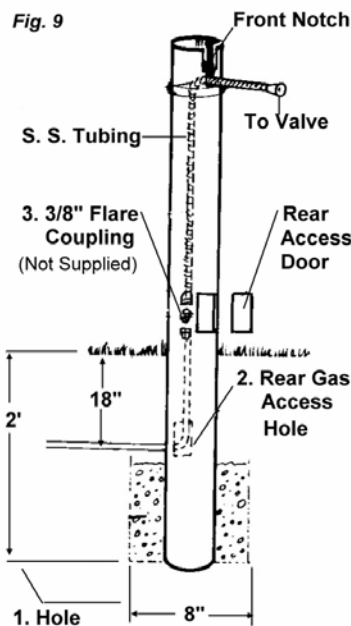

Step 2: Attaching The Grill Head Bottom To The In-Ground Post (Fig. 7 & 8)

Note: For Tube Bending see Page 24 Fig 47 in instructions. To attach the grill head to the post please refer to Step 3 of the Deck/Patio installation procedures on page 14 and follow instructions.

SPECIAL NOTE REGARDING TUBE BENDING: Tubing is made of a material that is easily bent to correct position. If you are doing this for the first time, you may wish to loosely pack the tubing with sand to give the sidewalls the rigidity to bend without kinking (see page 24 figure 49)

Stainless Steel and Aluminum Column To Base Kit Assembly Instructions

The A30 or A40 grill heads may be mounted on either the Stainless Steel (A-S PED) or Black Aluminum (A-B PED) column.

The gas supply may be LP or Natural as determined by the grill head.

The grill head should not be attached to the column until the column and the base kit (A-NB, A-LC or A-NC) is assembled together.

Please check to be sure that all parts are included before proceeding. Contact your dealer if any parts are missing.

Parts	Quantity
Column Box	
Stainless Steel Front Panel	1
Stainless Steel or Aluminum Column	1
Stainless Grease Cup	1
Tank Lock Bar	1
Hardware Kit	
Nylon Lock Bar Spacers	2
¼ - 20x1¼" S.S. Hex Head Bolts	4
¼ - 20 S.S. KEP Nuts	12
¼ S. S. Washers	10
¼ - 20 x ¾" S.S. Hex Bolts	8
Rectangular Washers	4
2-piece Gasket (Stainless Steel Column Only)	1
Aluminum Reinforcing Bar (Alum. Column Only)	2

Parts	Quantity
Base Box	
Cast Aluminum Base	1
12' Nat. Gas Hose/Quick Disconnect Hose	1
Above In A-NC Base Kit Only	
16" Hose & LP Regulator (In A30 or A40 LP Head)	
Stainless Steel Flexible Tubing, 28"	1
Above In A-NB Base Kit Only	
Axle	1
Axle Clips	2
6" Wheels	2
Hub Caps	2
Rotating Casters	2
Above 5 items in A-NC or A-LC Base Kit Only	

Note: While assembling, peel the thin white protective film covering from the stainless steel surfaces, especially in areas, which will be partially hidden after assembled. Do Not Scrape off.

Step 1: Connect the Tank Locking Bar (Fig. 10)

- From box Column Box locate and attach the Tank Lock Bar across the back of the pedestal column. Use the ¾" S.S. Hex bolt, Nylon Lock Bar Spacer and a Kep nut on each side to fasten the Tank Lock Bar in place. This spreads and holds the correct spacing at the back of the column.

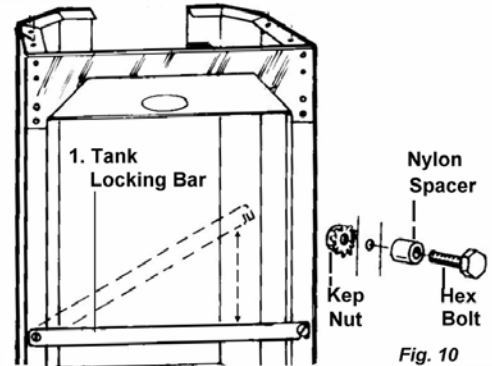

Step 2: Attach the Base to the Pedestal (Fig. 11)

- Before bolting the pedestal column to the base, the 2-piece gasket (stainless steel column only) must be installed to create a barrier between the two metals. Remove the backing strips from the gasket to expose the adhesive and stick the gasket to the bottom lip of the pedestal column. Make sure to align the holes.
- Attaching the pedestal column to the base will be easier to handle by laying the pedestal column face down and matching the holes on the pedestal column lip to the holes on the base. Use six ¾" bolts, four large rectangular washers, and on the underside six round washers and KEP nuts. **IMPORTANT:** the large rectangular washers are used at the sides on top of the pedestal column lip. The round washers and KEP nuts are used under the base. Tighten securely and stand unit upright.

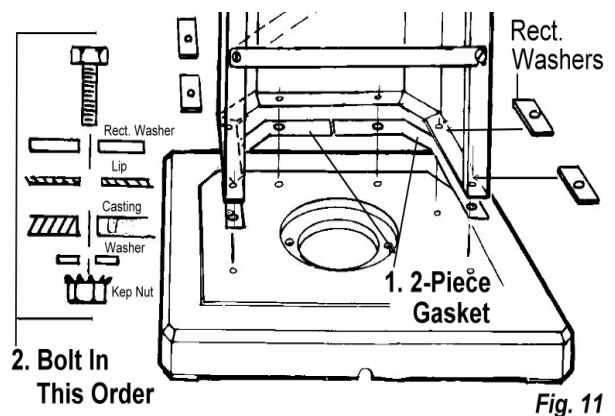

OPTION: For Portable Base Only A-LC & A-NC: (Fig. 12)

1. Attach the wheels by slipping the axle through the base, slide the wheels on and secure with the axle clips. Finish by snapping the hubcaps on before standing unit upright. For units with casters, place caster stem into stem opening of the portable base, press and snap into place. (Fig. 12)

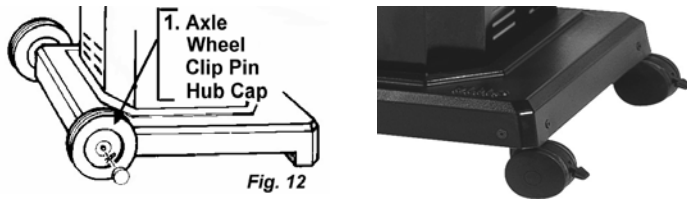

Fig. 12

Aluminum Column (A-B PED)

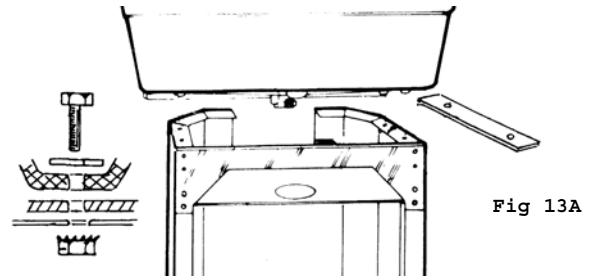

Fig 13A

Step 3: Connect the Grill Head Bottom to Column (Fig. 13)

1. Attach the grill head bottom to the pedestal column top with four ¼ - 20 x 1 ½" Hex bolts, washers under the bolt head and Kep nuts. Peel the remaining protective coating off the pedestal column.

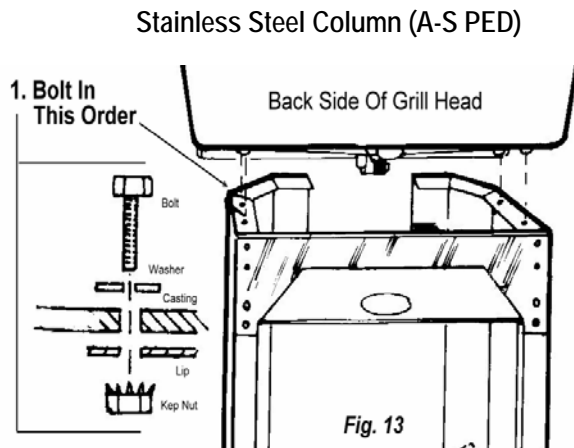
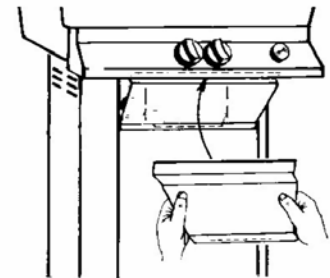

Fig. 13

Step 4: Attaching the Access Panel (Fig. 14)

Note: Do not attach the front access panel until the control panel has been attached to the grill head bottom and the gas supply line has been properly connected and leak tested.

1. The front access panel attaches directly under the control panel and hides the access opening. Lift the access panel up behind the lip of the control panel, then slip the bottom double edge of the access panel (upward pressure may be needed) over the edge of the access opening.



1. Access Panel Covers Access Opening

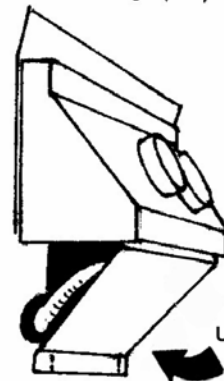

Upward Pressure

Fig. 14

Step 3: Connect the Grill Head Bottom to Aluminum Column (A-B PED) (Fig. 13A)

1. Attach the grill head bottom to the pedestal column top with four ¼ - 20 x 1 ½" Hex bolts, washers under the bolt head, reinforcing bar and Kep nuts. Note Reinforcing Bar used on the A-B PED Aluminum Column.

Grill Head Assembly Instructions

Step 1: Control Panel & Heat Shield

A. Attaching the Heat Shield and Control Panel Assembly (Fig. 19)

1. Attach the complete control panel assembly to the front of the grill head with 1/4—20 Kep nuts.
2. Leave the (2) nuts holding the heat shield on, to serve as spacer nuts.
3. Make sure the valve orifices on the control panel aligns with the burner venturi correctly and that the venturi tubes go over the valve orifices at least 1/4" to 1/2" (see fig. 22 on page 22).

CONTROL PANEL ASSEMBLY - Rear View

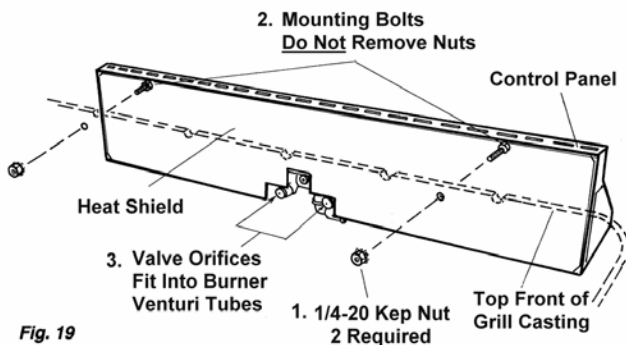

Fig. 19

B. Connecting the Control Panel Support Brackets (Fig. 20)

1. Two support brackets are connected beneath the control panel to the grill head for added support. Push a 1/4 - 20 x 1 1/4" Phillips head bolt through the grill head from the inside.
2. Slip the support bracket in position, fasten with a 1/4 - 20 Kep nut.
3. Attach the control panel to the support bracket by pushing up a 1/4 - 20 x 1/2" Phillips head bolt through the support bracket and through the lower lip of the control panel, fasten with a 1/4 - 20 Kep nut.

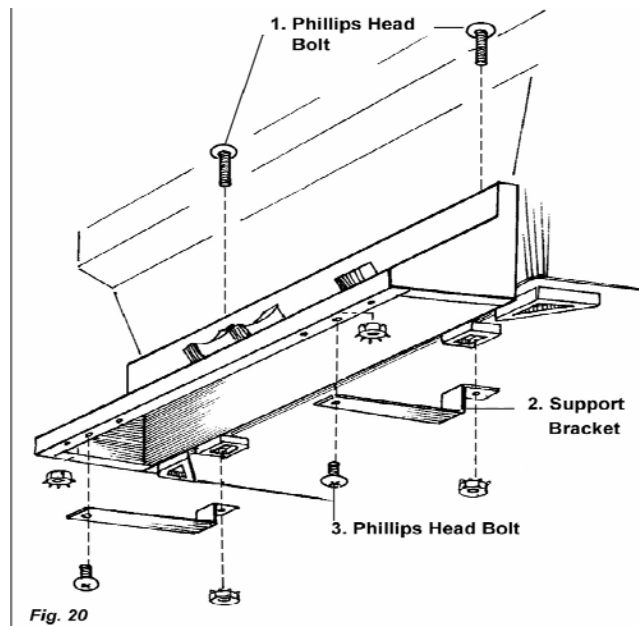

Fig. 20

C. Ignitor Wire Connection (Fig. 21)

1. Tip the grill on its back (or upside down) and attach the control panel ignitor wire to the terminal sticking out from the bottom of the grill. Be careful not to crack the delicate porcelain insulator.

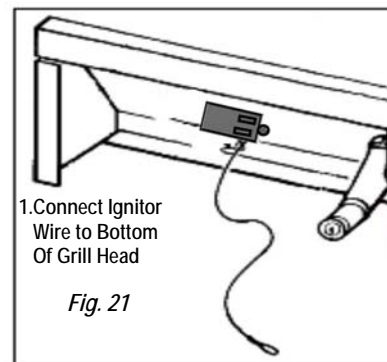

Fig. 21

Step 2: Connect the gas supply line

A. For LP Column Model A-LC:

1. Pass the 16" Hose and Regulator through the hose clamp ring and screw the ring to the front of the left leg.
2. Connect the regulator end of the hose to the LP-Gas Tank. Tighten securely and leak test both connections. See Leak Testing.

B. For Natural Gas Cart, Deck/Patio and In-Ground Mounts Using 12 foot Hose:

Connect one end of the supplied 12-foot hose to the grill valve connection behind the control panel. Then, connect the quick disconnect valve on the hose to the gas supply line connection. Tighten securely and leak test both connections. See Leak Testing.

Connect the 30" flexible tube to the incoming gas supply using a 3/8" flare coupling (not supplied). Attach the other end to the grill valve connection behind the control panel. To tighten securely use two wrenches. Hold valve joint with one wrench and tighten the hose fitting with second wrench. After Tighten leak test both connections. See Leak Testing

DO NOT USE COMPOUND OR TEFLON TAPE ON FLARE FITTINGS

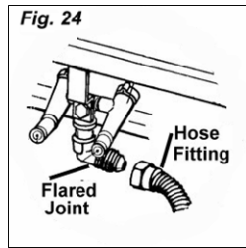

Stainless (A-S PED) and Aluminum (A-S PEDB) Column Mounts:

The supply line connection passes beneath the heat shield and through the front slot with the protected edge and attaches to the valve. Don't forget to attach the front Access Panel to the Column. (Fig. 25)



LP Propane for portable base and deck/patio mounts:

The hose connection from the Regulator passes out the front access opening; resting on the protected slot edge beneath the control panel. The LP tank-locking bar will press against the tank as it is lowered into place to prevent tank movement. (Fig. 26)

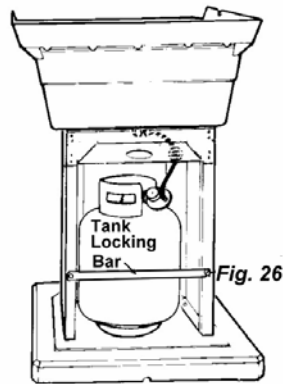

Natural gas for deck/patio mount:

The gas line enters at the rear of the base curving up through the base opening. The stainless steel flexible tubing line must be connected to the incoming gas line using a 3/8" flare coupling (not supplied by PGS). The flexible tubing then passes beneath the heat shield and through the front access opening and attaches to the control valve. (Fig. 27)

See tube-bending instructions Page 24 Figure 49.

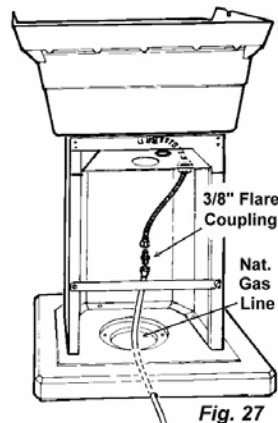

Natural gas or LP portable base mount:

The natural gas cart uses a 12 foot hose with a quick disconnect (supplied), the propane uses a 16" hose with LP Regulator. The hose



IGNITOR ASSEMBLY

PGS uses the finest electronic ignition available. Normal use will need to replace battery every six months, or whenever sparking sound gets weak or stops. To replace battery, simply unscrew cap found on top of control just below the word "Ignitor". Replace with a fresh AAA battery.

If ignitor does not produce a spark with a fresh battery, make sure that ignitor wire is plugged into back of ignitor as shown in Figure 21 on page 16 and also wire in securely plugged into ignitor box in figure 37 on page 20. NOTE: Replace battery when sparking sound either stops or noticeably slows down or every six months, whichever occurs first. If you are not going to use your grill for more than 30 days, remove the battery. Reinstall when you are ready to use your grill again.

SIDE SHELF ASSEMBLY

Install the left and right shelf brackets to the lower casting of your barbecue, using the four 1/4 X 20 X 3/4" hex bolts, secure with four 1/4" lock washes and four 1/4" hex nuts to hold each bracket (see Fig. 9). Attach shelf to the brackets by inserting the threaded screws on the shelf through the lower slots on the brackets. Let the shelf hang down. Attach the 10-32 Hex Nuts (see Fig. 30).



Figure 30 Installing Shelf Bracket
On portable models, this shelf, in the upright position, is to be used as a handle to move the barbecue

around. It is a sturdy handle properly hinged securely into place (see Fig. 31).

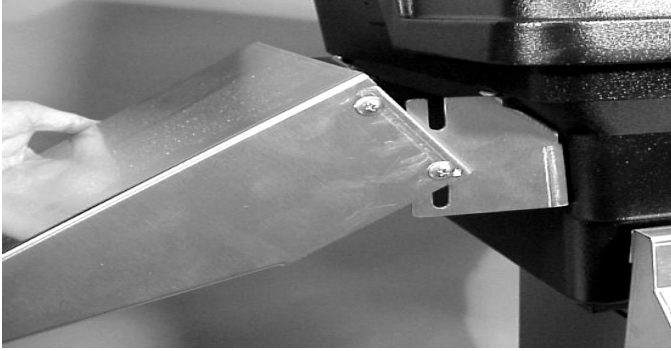

Figure 31

FINISH ASSEMBLY

1. Be sure to remove all plastic protective film. Place rock grate in the bottom of the casting.
2. Place ceramic "Moon Rok II" on rock grate by evenly placing side by side. See figure 32

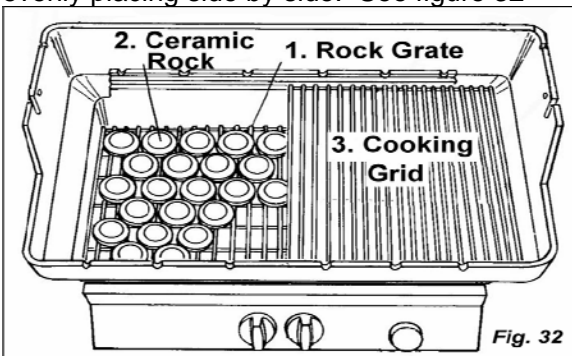

Figure 32 Proper placement of rock grates and "Moon ROK" and Cooking Grids

3. Place lid on lower casting. Insert hinge pins through top lid casting, then through pre-drilled hole in lower casting and attach cotter pins through hole in hinge pins to secure top to bottom casting (see Fig. 33).



Figure 33 Hinge Pins/Cotter Pins

5. Attach twin lid sides "Stay Cool" handles using 5/16" X 3/4" bolt and star washer, tighten securely.

6. Be certain that grease cup is secure in back of column.

7. Attach two control valve knobs to end of valve stems located in center of control panel. White mark should be pointing up to the OFF position.

LIGHTING YOUR GRILL



BEFORE ATTEMPTING TO LIGHT YOUR GRILL, INSPECT THE HOSE OR GAS SUPPLY. If it is evident there is excessive abrasion or wear, or the hose is cut, it must be replaced prior to the grill being operated. Please contact your local dealer/distributor for an exact replacement hose.

ALWAYS OPEN THE LID COMPLETELY BEFORE LIGHTING THE BURNER. This is to avoid trapping gas fumes, which could ignite. Do not stand with your head over the grill when lighting the burner.

- ✓ Open the lid. Examine the interior to be sure it appears normal.
- ✓ Turn control knobs to OFF position. Either control knob may be used when lighting your PGS gas grill.
- ✓ Turn gas ON at tank or supply.
- ✓ Turn either knob to Medium and gently push the red button on control panel ignitor module. You should hear the ignitor clicking and one half of the burner should be lit within four seconds. Turn the other control knob on "HI" and the other burner will cross light automatically.
- ✓ Visually verify that the burner lights and the flame is acceptable. Close the grill top and let the ceramic rocks get hot. Pre-heat the grill on HI with the lid down for five to seven minutes. This will ensure even heat and allow cooking at MEDIUM, for the most part.

WE STRONGLY SUGGEST OBSERVING GRILL FOR TWO MINUTES BEFORE LEAVING. SMALL LEAKS AND OR SPIDER FIRES CAN EASILY BE REMEDIED IF CAUGHT IMMEDIATELY.

IF THE BURNER FAILS TO LIGHT

Immediately turn controls OFF to prevent gas build-up. Wait five minutes for gas to clear and try the above procedure again. If the burner does not light with the electronic ignition, light the burner with a match or other hand held ignitor. On the right hand side of the lower grill casting, near the bottom, there is a match lighting hole (**see Fig. 34**). Raise the grill lid. Light a long match (or other ignitor) and turn the RIGHT hand control knob to HI. Insert the lit match (or ignitor) into the hole to the end of the burner and light the grill. Under some adverse wind conditions it

may be necessary to turn the grill or to light the burner via a vent opening under the grill head.

DO NOT TOSS A LIT MATCH INTO THE UNIT AND TURN THE GAS ON!

IF THE GRILL STILL FAILS TO LIGHT, CHECK THE GAS SUPPLY. YOU COULD BE OUT OF LP GAS OR THE MAIN GAS SUPPLY FOR NATURAL GAS MAY HAVE BEEN TURNED OFF. IF THE LP TANK HAS GAS OR THE NATURAL GAS IS TURNED ON AND THE GRILL STILL WILL NOT LIGHT: CHECK THE ELECTRONIC IGNITOR TO MAKE SURE IT IS SPARKING. IF NOT, CHECK THE BATTERY IN THE MODULE AND ALSO MAKE SURE THE IGNITOR WIRE IS CONNECTED BOTH TO THE MODULE AND TO THE BOTTOM OF THE ELECTRODE.

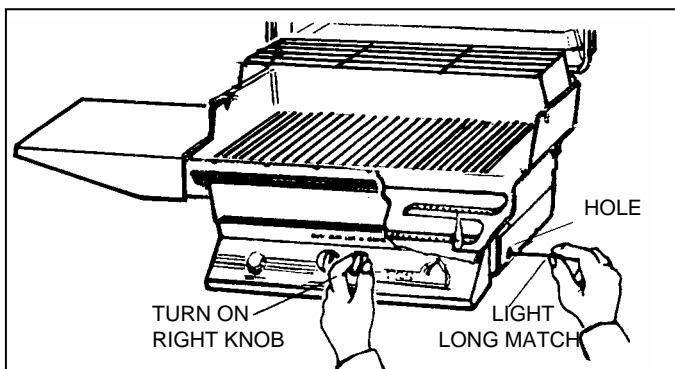

Figure 34 Manual Lighting of Grill

PERIODIC CLEANING

Knowing how to remove and replace the burner allows you to easily and thoroughly clean your grill. Even though "Burning Off" the grill after every cookout will keep it ready for instant use, once or twice a year you should perform basic maintenance to keep your grill in top operating condition.

BE SURE THAT YOUR BARBECUE IS COLD, GAS SUPPLY IS OFF AND THAT YOUR FEEDLINE IS BLED OF ANY GAS.

1. After removing cooking grids, ceramic rock and rock grates, remove your burner assembly by first carefully disconnecting the lead wire from your ignitor module. Gently pull the burner forward to release the spring clip, then pull the burner assembly forward and up. Cover the valve orifices with a small piece of aluminum foil to keep out dirt. Brush both sides and the bottom of the burner with a stiff wire brush. Any clogged flame holes may be opened using a thin wire. Use a venturi brush (or bottlebrush), pipe cleaner or long flexible wire to clean out the venturis. Since the grill housing is heavy rust-free cast aluminum, you are only trying to remove built up grease and debris.

2. DO NOT DAMAGE THE CERAMIC PROBE OR COLLECTOR BOX.

After cleaning burner assembly and the lower casting of grill, reinstall burner to lower casting.



TURN YOUR GAS SUPPLY (LP OR NAT) ON AND TEST ALL FITTINGS FOR LEAKS. BEFORE ATTEMPTING TO LIGHT GRILL, BE CERTAIN BOTH VALVES ARE IN THE OFF POSITION. TURN GAS SUPPLY ON (leaving both control knobs in the "OFF" position). CHECK ALL CONNECTIONS WITH A SOLUTION OF 50% LIQUID SOAP, 50% WATER. SOLUTION CAN BE SPRAYED ON WITH A SPRAY BOTTLE OR PAINTED ON ALL CONNECTIONS WITH A BRUSH. IF BUBBLES APPEAR, TURN OFF GAS, TIGHTEN FITTINGS AND TRY AGAIN. BE SURE ORIFICES ARE ENGAGED INTO THE BURNER VENTURIS.

3. The exterior of your grill has been powder coated and baked with a special high temperature powder process that seals the paint to the grill housing. The grill will retain its appearance with a little care. Occasional white oxidation may be washed off with a mild soap and warm water. Once oxidation is removed, turn your grill burners to low heat, close lid and allow to heat up for FIVE MINUTES. After grill housing is WARM apply a small amount of vegetable oil or PGS Stainless Steel Cleaner with a clean lint free cloth and apply evenly to grill housing. This method will keep your grill looking new for many years.

We also recommend keeping your grill covered at all times, when not in use.

For stubborn cases, high temperature touch up paint can make an old grill appear new. Allow 24 hours for paint to dry before using grill.

4. If your pedestal is black aluminum you can protect this with a car finish protectorate. If you have a stainless support use a good grade of stainless cleaner such as our PGS "SSC" (Stainless Steel Cleaner).

5. To maintain cooking grids, we recommend brushing with a grill cleaning brass brush after grill has completely cooled. A light vegetable oil on grids just before cooking will prevent food from sticking to the surface. NEVER PLACE COOKING GRIDS IN A SELF-CLEANING OVEN. If grids are very dirty, you may want to see your PGS Dealer for a commercial quality grid cleaner. Be sure to oil before using.

FLASHBACK

In many areas, spiders or small insects have been found to create "flashback" problems. The spiders spin webs and/or insects build nests in the grill's venturi tube(s). The web and/or nests can lead to gas flow obstruction, which can damage your grill as it results in a "flashback" (a fire in the venturi tube(s)). The grill may still light, but the obstruction does not allow full gas flow to the burner. Therefore, some gas will back up and escape at the venturi air shutter. This will ignite, causing flashback, which could also damage your grill (see Fig. 35 & 36).

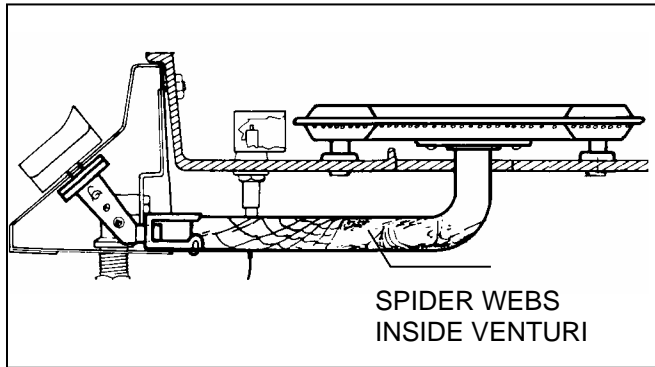

Figure 35 Spider webs inside venturi

Your PGS grill has fine mesh brass screening placed around the burner venturis to minimize this problem. Please DO NOT damage or remove these screens when you clean your burners.

If you live in an area where spiders are plentiful, you should make it a point to clean the venturis often. You may want to spray around the bottom of your base with an insect repellent on a regular basis.

PLEASE BE CERTAIN TO KEEP THEM AWAY FROM ANIMALS AND CHILDREN.

TO CLEAN BURNERS OF SPIDER WEBS SEE INSTRUCTION #1 OF PERIODIC CLEANING.

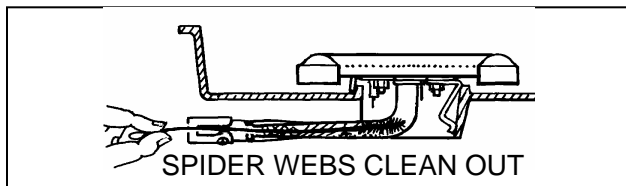

Figure 36 Venturi cleaning out

BEFORE LIGHTING YOUR GRILL:

TURN YOUR GAS SUPPLY (LP OR NAT) ON AND TEST ALL FITTINGS FOR LEAKS. BEFORE ATTEMPTING TO LIGHT GRILL, BE CERTAIN BOTH VALVES ARE IN THE OFF POSITION. BE CERTAIN THAT YOUR GAS SUPPLY IS OFF AND YOUR GAS FEED LINE HAS BEEN BLED OF ANY FUEL. WHEN REINSTALLING BURNER, BE CERTAIN THAT THE BURNER VENTURIS ARE ENGAGED ON THE VALVES AT LEAST 1/4". TO

TEST FOR GAS LEAKS TURN GAS SUPPLY ON (leaving both control knobs in the "OFF" position) AND CHECK ALL CONNECTIONS WITH A SOLUTION OF 50% LIQUID SOAP, 50% WATER. SOLUTION CAN BE SPRAYED ON WITH A SPRAY BOTTLE OR PAINTED ON ALL CONNECTIONS WITH A BRUSH. IF BUBBLES APPEAR, TURN OFF GAS, TIGHTEN FITTINGS AND TRY AGAIN.

ELECTRODE ADJUSTMENT

On model A30 & A40 there is an electrode, inside the collector box, it is adjusted and checked at the factory for optimum spark. The tip is 1/8" from the inside surface of the collector box. In the event that the ceramic insulator should crack and need replacement, the collector box is easily removed by removing the large nut holding it to the bottom grill casting. The grill head must be removed from the pedestal support to replace the collector box (electrode and collector box are one unit).

Check the new part for proper spacing of the electrode end before installing. Since the feed-through fixture is threaded its full length, loosening and tightening two jam nuts will move the electrode tip closer or farther away from the collector box surface. For best spark, set at 1/8" (see Fig. 37).

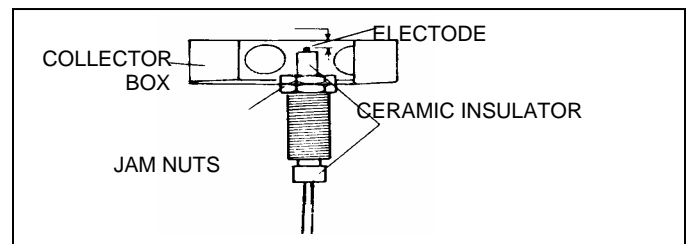

Figure 37 Proper electrode adjustment

NOTE: Replace battery when sparks noticeably slows down or every six months (depending on usage). If you are not going to use your grill for 30 days or more, remove battery.

FLARE-UPS

When you cook fatty foods over an open flame, you can expect flare-ups. Natural juices falling on the hot ceramic rock results in flame and smoke that give foods cooked on your grill that delicious outdoor flavor and appearance. Expect and encourage a MODERATE amount of flare-up. We suggest that you trim off excess fat before cooking. Excessive flare-ups occur when cooking extra fatty foods, or if

cooking temperatures are too high. To control flare-ups:

1. Turn your control knob to a lower heat setting.
2. Move the meat to another part of the grill, if possible. With a dual burner, you can cook on one side and move food, as necessary to the unlighted side or lower heat setting.
3. Cook with the lid open to reduce heat inside of grill head. Periodically flip rock so that it will self clean residual grease build-up.
4. If you need to immediately control any excessive flare-up, spray the flame with water or throw a small amount of baking soda directly on briquettes (avoid baking soda on food).

GREASE CUP CLEAN OUT

We recommend periodic inspection and clean out of the grease cup with your PGS gas grill.

FLAME ADJUSTMENT TIPS

Your PGS burner has been designed to operate efficiently under widely varying operating conditions and is adjusted at the factory for proper operation so no adjustments should be required. Occasionally, vibration during transport or variations in local fuels and gas pressure, altitude, or other external conditions might require minor burner adjustments. Sometimes your burner will burn differently if your propane cylinder has been recently filled or it is near empty. Sometimes air will need to be purged from your natural gas line.

A qualified technician should make burner adjustments at the time of installation. Extreme care should be exercised if adjustments are required after installation. If you need to inspect and adjust burners while unit is operating:

Carefully remove rock grates, cooking grids, and rock from bottom casting. Burner adjustments can be best performed in low light and in **non-windy conditions** so you can properly view burner operation and make proper flame adjustments. Turn gas supply on and light grill as usual.

Inspect the burner when it is on low. Flames should be mostly blue and stable. The flame tips will be yellow at the ends and this is normal. When you re-install the rock grates the burner flames impinging on the rock grates will also cause the flame pattern to appear more yellow, this is normal and does not in any way affect the performance of your grill. A burner in an outdoor appliance operates in a different environment than an indoor appliance burner or flame and as a result will visually look different.

If you see the flames lifting from the burner, or only parts of the burner are burning, or if you hear excessive noise from the burner, please check the following: valve/orifice engagement in the venturis, that the burner is level in the casting, and also check burner tubes to be certain they are not obstructed with debris or spider webs. These conditions will more often be the case than the burner being out of adjustment. If you feel that you do need to adjust the burners please follow directions below when burners are cool to the touch:

1. Disconnect ignition wire at module. Disengage your burner by unclipping it from the rear and lifting forward and up.
2. At the end of each of the burner venturis you will see an air mixer secured by a small setscrew. When the screw is loosened the air shutter can be rotated to allow more or less air.
3. If the flame is extremely yellow this indicates the burner is getting insufficient air. Turn the air mixer to the open position to allow more air to the burner. Tighten screw to insure mixer stays in this position.
4. If the flame is noisy and tends to lift away from the burner tube there is too much air being fed to the burner. Turn the air mixer to reduce the opening and air volume to the burner. Tighten screw to insure air mixture does not move.
5. Reinstall burner and light as normal and inspect flame. If burner requires additional adjustment repeat above procedure. There is not a significant degree of adjustment required to these burners.

Differences in altitude, operating conditions, weather conditions; gas pressures, odorants and stabilizers used in both natural gas and propane will often cause burners to burn differently. As long as you are getting good ignition, even cooking performance, and the burner flame is blue with yellow tips and operating consistently, you should not have to adjust the burners.

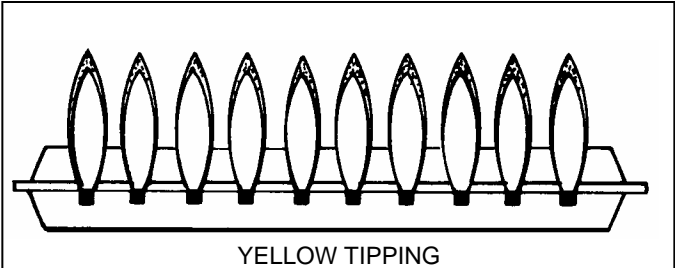

Properly adjusted burner

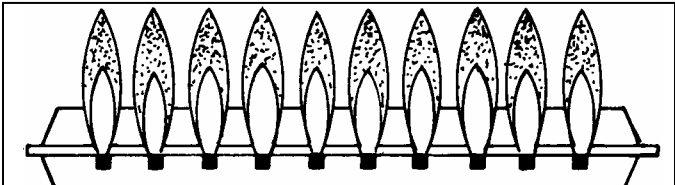

NORMAL HARD FLAMES

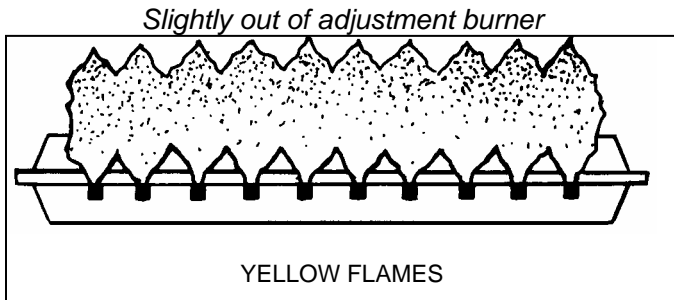

Extremely out of adjustment burner

VALVE

VENTURI

GAS
LINE IN

VALVE
ORIFICE

AIR
SHUTTER

Figure 38 Proper orifice engagement

At the end of each valve there is a tiny gas opening known as an orifice. Gas exits the orifice and enters the venturis where it mixes with air. The proper mixture of gas and air produces a clean blue flame with slight yellow tips from the burner.

HELPFUL TIPS

1. Before using your grill for the first time, please light and turn both burners on HI heat for ten to fifteen minutes. This will burn off any oils that are on new surfaces. Before grilling, we suggest putting a light coat of vegetable oil on your cooking grids. This should be done before you turn on your grill. A spray on oil, safflower or similar oil will work just fine.

2. Burning unit after each use is not required or recommended. Extended burning may cause premature wear on components or may damage your unit if left unattended. Pre-heating grill 5-7 minutes before each use will burn off most residue.

After the cooking grid has cooled, we recommend that you lightly rub the cooking grid with a nylon cleaning pad or similar material to remove any baked on foods. Please remember to lightly oil the cooking grid with a spray on oil, vegetable or safflower oil before using the next time.

If your grids have a lot of food on them, you may want to put them in a plastic bag with a cup of ammonia and leave them in the sun for a day... be sure to wash them thoroughly before using.

YOU MAY CLEAN YOUR STAINLESS STEEL COOKING GRIDS WITH A BRASS WIRE BRUSH. DO NOT PLACE COOKING GRIDS, ROCK GRATES OR ROCK IN A SELF-CLEANING OVEN.

ALWAYS KEEP YOUR GRILL COVERED WHEN NOT IN USE.

ORIFICE ENGAGEMENT

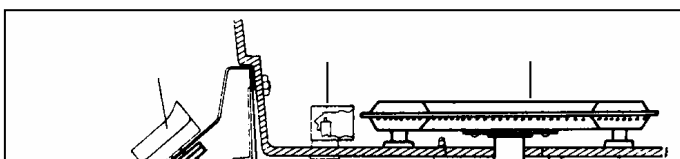

BE CERTAIN THAT ORIFICES ARE ENGAGED INTO THE BURNER VENTURIS (see Fig. 38).

Proper orifice engagement should be 1/4" to 3/8" into the venturis.



FAILURE TO PROPERLY ALIGN THIS CONNECTION MAY CAUSE A FIRE AND RESULT IN DAMAGE TO YOUR GRILL.

GAS CONNECTION WILL REQUIRE LEAK CHECK UPON ASSEMBLY COMPLETION.

GAS GRILL CONVERSION

We strongly recommend having your gas grill converted by a servicing dealer, your local gas utility or other trained personnel.

PGS TROUBLESHOOTING GUIDE

No Flame	Gas Shut off Obstruction in Orifice(s) Leak in Gas Train No Gas in Tank or Not Connected to Gas Source
Low Flame	Leak in Gas Train Obstruction in Orifice(s) or venturi's Natural Gas valve only turned part way Burner gasket plugging venturis.
High Flame	Wrong Orifice Size for style Gas Venturi Air shutter needs adjustment Burner split
Flames out the Control Panel	Spider webs in Venturi tubes see page 20
Valve knobs won't turn	Spider fire burnt out lubrication in valve Lubrication dried out
Warped or bubbled Lower Casting	Burner burnt out and emitting too much flame in one area melting casting. Burner left on for extended period of time Wrong rock in casting causing build up of heat and melting casting Venturi tubes not lined up with gas valves
Stainless Steel rusting	Grill placed near pool chemicals
Paint peeling	Aluminum Base – sprinkler/animal urine/chemicals
Grill won't light w/module	No sound from Module – replace battery Slight sound – cracked electrode or crack in wire - After dark – look for spark
Electrode Missing from Collector box	Electrode clip gave way and electrode fell out
Upper casting tipping or not fitting	Holes for hinge pins are uneven, casting rear edge bowed or uneven

PROPER TUBE BENDING

For 2' & 4" Posts With Access Doors.

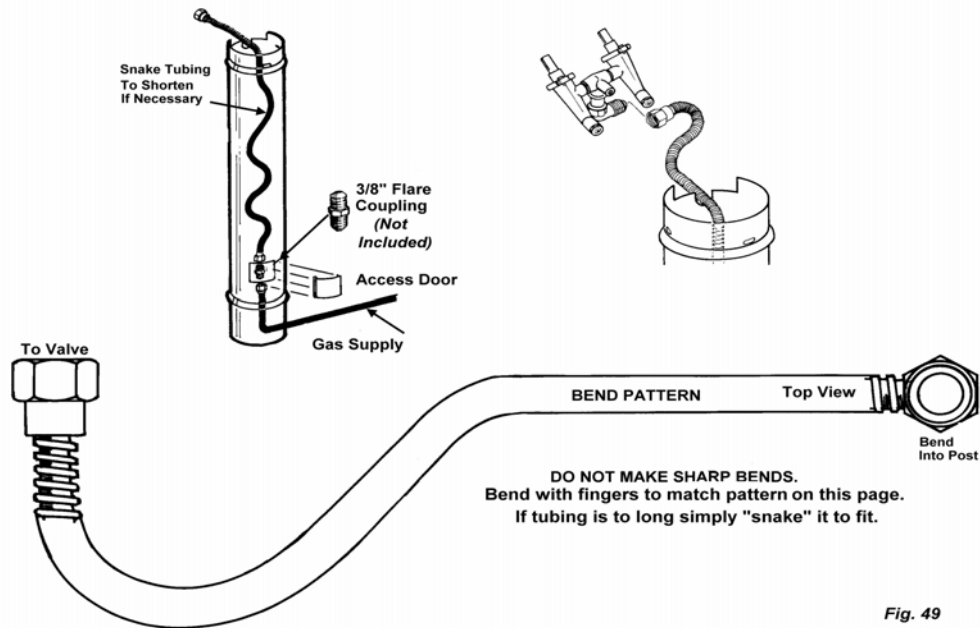

Fig. 49

BEEF COOKING GUIDE (Grill Preheated 5-10 Minutes)

<u>Item</u>	<u>Amount of Meat</u>	<u>Heat Setting</u>	<u>Cooking Time for Medium Doneness</u>	<u>Cooking Tips and Methods</u>
Hamburgers	1/2 lb.	Medium	8-10 minutes	Grill with hood closed, turn once
T-bone or Porterhouse Steaks	1 to 1.5 lb.	Medium	8- 10 minutes	Trim off excess fat, cook with hood closed minimize flare up, turn steaks once
Sirloin Steaks	1 1/2 " thick	Medium	15-18 minutes	Same as above, sear meat quickly on HI then reduce heat
Top Round	1 1/2 " thick	Medium	18-22 minutes	Marinate first, cook with lid closed turn only once.
Flank	3/4 " thick	High	10-13 minutes	Marinate or tenderize, score with diamond pattern, cook with lid closed, turn once.

POULTRY COOKING GUIDE

Poultry, unlike beef, requires that meat be fully cooked. The guide below is only a guide; please use a quality thermometer whenever you are cooking poultry to insure proper doneness.

<u>Item</u>	<u>Amount of Meat</u>	<u>Heat Setting</u>	<u>Cooking Time for Medium Doneness</u>	<u>Cooking Tips and Methods</u>
Chicken Pieces	2 1/2 lb. to 5 lb. Serves 4 to 8 people.	LO	34-45 minutes	Preheat grill for ten minutes, grill chicken until juices run clear, turn frequently, brush with sauce during last 15 minutes if c
Whole Chicken	2 1/2 to 3 lb. (broiler-fryer)	Medium	60-75 minutes	Remove cooking grid, center chicken on rotis spit. Place drip pan on rocks. Balance chicken on spit rod, tie legs and wings close to body, rotis until internal temp. reaches 185 degrees. ALWAYS USE A MEAT THERMOMETER (ask you dealer about our "INFRA BROIL" rear burner kit... there is nothing like it for rotis cooking)

PACIFIC GAS SPECIALTIES COOKING TIPS AND TEMPATURE GUIDE

Cooking outdoors has truly come of age in America. What was once a frustrating experience, pitting the weekend chef against a raging charcoal inferno has evolved into an enjoyable culinary experience. Outdoor cooking has no equal in terms of flexibility, flavor, creativity or exciting presentations. "Cooking with gas" makes your outdoor cooking easier and more fun than ever! Unlike cooking with charcoal, YOU control the process rather than the process controlling YOU. Your PGS Legacy Gas grill has modern, safe, and convenient continuous spark ignition for safe lighting. Our "Performance Grilling System" has been designed to give you excellent cooking results with a minimum of hassle. You can cook outdoors year 'round!

Clean up is a snap with your grill. No charcoal mess, ashes, or bothersome clean-up procedures! Since you'll be cooking outdoors, you will save energy by keeping the heat outdoors. After only a short time you will be able to cook all parts of your meal outdoors on the grill.

SOME BASICS

What makes outdoor barbecuing truly unique is the cook! Your PGS grill will provide you with control and flexibility beyond your expectations. There are a few basics that will help you maximize the design features of your grill. The truly masterful outdoor chef is one that masters the art of heat control. The outdoors temperature, wind conditions, gas pressure, location, and other factors all play a part in the outdoors cooking experience. On cold, windy days the heat setting specified in our recipes might be a bit low. Just turn your heat controls to a slightly higher setting to compensate. The opposite will hold true in warmer climates or on windless days. Your own personal tastes in terms of "doneness" will also allow you to make adjustments in the cooking process.

HOW ABOUT THE FUEL SOURCE?

Your PGS outdoor gas grill operates equally well on either propane or natural gas fuel sources. If you have any questions about your fuel source please call your local LP or natural gas utility company BEFORE operating your appliance. Our assembly instructions also discuss the differences between the two gases. Both sources of fuel are environmentally positive, safe, convenient, clean burning, and efficient.

ADJUSTING THE FLAME

Every PGS grill is factory set and pre-checked to operate efficiently at sea level. If you live in a high altitude area you might have to adjust your grill slightly. Perhaps the most frustrating experience is to over cook your meat, poultry, fish, or vegetables because of excess heat. Only experience and getting to learn to use your grill will eliminate this from happening. Let's discuss the various heat settings.

The "HI" Setting

Pre-heat the ceramic briquettes and cooking grids in your grill. This setting may also be used for quick searing of meats. The "HI" setting should also be used for about ten minutes after using the grill to self-clean the cooking grids and ceramic briquettes. Your PGS grill has

been designed to heat quickly using minimal amounts of fuel. Cooking on HI with the lid closed is not recommended unless you want to cook very quickly for only a short time. With the lid closed, cooking temperatures will exceed 700 degrees F... that's HOT!

The "MEDIUM " Setting

The medium setting between "HI" and "LO" can be used for most meals including steaks, chops, burgers, fish, etc. The medium setting may also be used to sear foods that have been cooked initially on the "LO" setting. Cooking with the lid open or closed is a matter of personal preference and will often be dictated by wind conditions on your patio. Cooking with the lid closed will create internal casting cooking temperatures of approximately 550 to 600 degrees Fahrenheit. Experiment with cooking with the lid open or closed and you'll quickly choose a preference. Half the fun of outdoor cooking is the experimentation. The other half will be the great cooking results you will get time and time again!

The "LO" Setting

Your PGS has an "infinite" heat control which allows you to control the heat output on one or both burners on "HI", "LO" or medium or anywhere in between. The "LO" setting is the preferred setting for most foods. Even thicker cuts of steak which have been seared on both sides on the "HI" setting will cook with a better texture and retain the juices better when cooked on the "LO" setting.

Operating the grill with both burners on the "LO" setting will create a temperature between 350 to 400 degrees F. This is perfect for roasting, baking, and rotissing. Depending on the draft or wind conditions, propping the lid up slightly will change the heat level slightly for even greater control. Again, the only limit to the flexibility of your grill is your imagination.

HOW ABOUT FLARE-UPS?

Some flare-up should not only be expected but is desirable in most outdoor cooking. The key is to control the level of the flare-up. Your PGS Grill has been designed to allow you to control the level of the flare-ups. The stainless steel grids that hold the rock and the ceramic rocks themselves have been designed to give you unequalled even cooking and flare-up control.

These two materials will become super-heated and when the fats and juices drop on the rocks and grates the majority will be vaporized and create that "outdoor" taste. When you notice the flare-up becoming excessive turn the heat setting to the low position. If the flare-up persists a hand held water sprayer may be used to dampen excessive flare-up.

The lower casting of your PGS grill has been specially designed to channel excessive fats and juices out of the bottom casting and into the grease collection tray. Please be sure to check the grease tray on occasion and clean when required. If you find that you are getting too much flare-up it is generally the result of cooking with the grill too hot... the solution is to reduce the heat output.

When rotissing you may want to put an aluminum tray or drip pan under the cut of meat to capture the excessive fats and juices to further reduce flare-up. Again, flare-up is desirable when it is under your control.

HEAT OUTPUT VARIATIONS

No two gas grills will perform exactly the same way. The fuel source, line pressure or volume, method of installation, wind and weather conditions all contribute to influencing heat output and control. Irrespective of the cooking appliance cooking will always be more art than pure science.

Even slight breezes across the cooking grids will cause a temperature variation of 25 to 50 degrees. Your unit should be positioned so the wind is at the back of the grill-cooking surface. The top casting will help shield the unit from the wind. Even though your PGS grill has been designed to cook extremely evenly you might experience slight variations in heat at the cooking grids. Your variably spaced cooking grids will give you increased flexibility in this area. You should cook smaller more delicate foods like shrimp, fish, vegetables etc. on either side of your grill over the grids that have been spaced closer together. These grids allow fewer flare-ups and will prevent smaller items from falling through the grids without the use of additional add-on accessory grates or griddles. Experiment with these areas, we're sure you'll like the results!

COOKING DIRECTLY

Cooking directly on the cooking grids is by far the most frequently used outdoor cooking method. This method is ideal for chicken, fish, burgers, shish-ka-bobs, and the list goes on and on. Meats get that great outdoor taste when the meat's natural juices drip down on the hot ceramic briquettes, caramelize, and impart that great outdoor taste. As we discussed earlier, flare-up is to be expected and is actually desirable. If you get a bit too much during the cooking process, rearrange the foods and just turn down the heat.

When the hood is closed your grill will cook faster, remain at a more controlled temperature, and use less energy. A great way to determine doneness, especially on thicker cuts of meat or poultry, is to use a meat thermometer with a probe. You can also use accessory items such as grill baskets, shish-ka-bob skewers, woks, griddles, skilletes, casserole and baking dishes directly on your cooking grids. Get creative, experiment, and have lots of fun!

COOKING WITH A ROTISSERIE

One of the most flexible accessory items for your grill is the motor-driven rotisserie. Use the rotis to thoroughly cook larger cuts of meat and whole poultry. A turkey cooked to golden perfection on the grill is a real treat. You can keep the lid closed when using your rotisserie. As the rotis slowly turns, the meat will self-baste in its' own juices or you can add your own favorite sauce or marinade. The rotis will give you moist and flavorful results with just a little practice. Just remove your cooking grid or grids to accommodate the cut of meat. Insert a shallow drip pan directly on the lava rock to catch the juices and drippings. You can use these in a gravy or sauce later if desired. A meat thermometer with a probe will give you an exact indication of proper cooking times and temperatures.

INDIRECT COOKING

You can bake or roast foods in your PGS grill just like you would in a conventional oven. Casseroles, whole poultry, breads, and cakes can be cooked using this indirect method. As the name implies, the food is not cooked directly over the heat source. Instead it cooks by heated air circulating inside the grill casting. Just fire the grill on one burner and put the food on the opposite grid.

Place an oven thermometer on the unlit side of the grill while cooking indirectly. Regulate the temperature control to the desired cooking temperature. Your grill is an ideal alternate cooking source during the busy Holiday Season. Always keep the lid closed when cooking via the indirect method.

Use the following chart as a basic guide to cooking indirectly with the lid closed. If you are grilling on a very hot or cold day you will have to adjust the temperature setting up or down as required.

TEMP. GUIDE (INDIRECT COOKING)

GRILL	CONTROL	
<u>TEMP.</u>	<u>SETTING</u>	<u>ITEM</u>
275-350	LO	Smokes Foods, rolls, leftovers
350-425	MED	Roasts, Ribs, Fish, Poultry, Meat Loaf, Cakes Pies, Cookies, Casseroles
425-450	HI	Biscuits, Pizza, Rolls

THE MICROWAVE GRILL COMBO

Your PGS Gas Grill and indoor microwave are a great combination. Many meals that require long cooking times or defrost times may be started in the microwave and finished up on the grill. The convenience of the microwave and great taste of the outdoor grill are an unbeatable combination for those with busy schedules. Using the microwave to defrost means that you can literally go from the freezer to the grill in a matter of minutes.

Poultry, ribs, and other foods that normally take between 45 minutes and one hour to grill may be cooked by microwave for ten minutes (or to your taste) and then finished on the grill. The opposite method may also be used. Foods may be partially cooked on the grill and then frozen to be thoroughly cooked in the microwave at a later date. When you rotis a chicken do two instead and freeze one for a later meal.... this will be a real hit!

Large amounts of food for a large party may be pre-cooked in the microwave then quickly seared on the grill. Get creative with these two outstanding cooking appliances to get more enjoyment and flexibility out of each appliance.

THE CALORIE/CHOLESTEROL PICTURE

It is beyond the scope of this guide to be an authority on the latest in calorie counting or cholesterol reduction. However, there are some basics that should be remembered. Outdoor cooking can be done with no added cooking oils or fats. Marinades and sauces may be made oil-free and salt free and still do an excellent job of flavoring meats, poultry, and seafood.

Warranty

PLEASE NOTE: ENCLOSED WARRANTY REGISTRATION CARD MUST BE RETURNED TO PGS FOR WARRANTY TO BE IN PLACE. PGS WILL NOT USE WARRANTY INFORMATION FOR ANY PURPOSE OTHER THAN INTERNAL REGISTRATION OR BULLETINS REGARDING PRODUCT IMPROVEMENTS.

PGS gas grills are made of the finest materials available. They are designed for use in a residential setting and not intended for commercial installations. Warranty information below applies to residential use. Commercial, common areas or apartment use carry no warranty

LIFETIME WARRANTY

Pacific Gas Specialties warrants to the original consumer that the upper, lower, housings, stainless steel cooking grids, stainless steel warming rack will be free from defects in material and workmanship (excluding normal discoloration) when subjected to normal domestic use and service for the life of the grill.

10-YEAR WARRANTY

Pacific Gas Specialties warrants to the original consumer that the stainless steel cart, stainless steel side shelves, "Flare Guard" radiant shields, stainless steel Burner assembly and brass valve assembly will be free from defects in material and workmanship when subjected to normal domestic use and service for a period of ten years from date of original purchase. Please note, these materials will discolor. The finish will change with long-term use. The warranty does not cover rust or oxidation of these materials.

1-YEAR WARRANTY

Pacific Gas Specialties warrants to the original consumer that the electronic "Sure Start" ignitor, all galvanized steel components, and all other parts not previously noted will be free from defects in material and workmanship when subjected to normal domestic use and service for a period of one year from date of original purchase.

WE STRONGLY RECOMMEND THAT YOU PURCHASE A PGS GRILL COVER TO PROTECT THE FINISH OF YOUR GRILL WHEN NOT IN USE. This warranty does not include the cost of any inconvenience or property damage due to failure of the product, and does not cover damage due to misuse, abuse, accident, damage arising out of transportation of the product, or damage incurred through commercial use of the product. This express warranty is the sole warranty given by the manufacturer and is in lieu of all other warranties, expressed or implied, including implied warranty of merchantability or fitness for a particular purpose. If you experience a warranty problem, please contact your local dealer who can exchange warranty parts. Please note that proof of purchase such as copy of sales receipt will be required. If you wish to handle your warranty claim directly with the factory, please call us at the phone numbers listed below. Upon receipt of the defective part, proof of purchase, and a check in the amount of \$25.00 for handling, we will repair or replace part and ship you replacement parts freight prepaid.

PGS BY AEI CORPORATION
2641 DU BRIDGE AVE.
IRVINE, CA. 92606-5001 (949) 474-3070 FAX 949 474-0559 E MAIL aeicorp@sbcglobal.net